



REPLACEMENT PARTS CATALOGUE

FOR

1972 MODELS
30_{CU.IN.} [500_{C.C.}]

DAYTONA T100R
TROPHY 500 T100C

U.S.A. EDITION

99-0954



REPLACEMENT PARTS CATALOGUE

FOR 1972

DAYTONA (T100R) TROPHY 500 (T100C)

TRIUMPH ENGINEERING COMPANY LIMITED
MERIDEN WORKS · ALLESLEY · COVENTRY CV5 9AU · ENGLAND

TELEPHONE COVENTRY 20221
MERIDEN 331

TELEGRAMS "TRUSTY" COVENTRY
TELEX "TRUSTY" 31305

ADVANCE INFORMATION

The Triumph Engineering Co. Ltd. point out that the information contained in this catalog was complete and correct at the time of printing. Distributors will be informed of any subsequent alterations.

A plastic binder, of the type used for Workshop Manuals, is available to enable this catalog and all other 1972 season catalogs to be bound into one unit.

GUARANTEE

Please refer to your local dealer or distributor for the latest terms of guarantee.

EASTERN U.S.A. DISTRIBUTOR:

Triumph Motorcycle Corporation,
P.O. Box 6790,
Towson,
Baltimore 4,
Maryland 21204.

Telex—Tricor Balt. 87728
Telephone—301-252-1700

WESTERN U.S.A. DISTRIBUTOR:

Triumph Motorcycle Corporation,
P.O. Box 2765,
East Huntington Drive,
Duarte,
California 91010.

Telex—Tricor Duarte 675469
Telephone—213-359-3221
213-681-0255

ENGINE AND FRAME NUMBERS

The engine number is located on the left side of the engine, immediately below the cylinder barrel to crankcase flange.

The frame number is located on the left side of the frame headlug, beneath the fork top lug and forward of the gasoline tank.

Both the engine and frame number should be quoted in full in any correspondence relating to the machine.

INDEX

	<i>Page</i>		<i>Page</i>
AIR FILTER	67	HANDLEBARS	69
ALTERNATOR	9, 35	HANDLEBAR MOUNTINGS	69
AUTO-ADVANCE UNIT	25	HEADLAMP	73, 77
		HEAT SINK	75
		HORN	75
BATTERY CARRIER	67		
BRAKE SWITCHES	45, 73	KICKSTARTER	31
BREATHER PIPES	65		
		MANIFOLD	15
CAMSHAFT, INLET AND EXHAUST	9	MUFFLERS	37, 41
CAPACITOR, IGNITION	73		
CAPACITOR PACK	73	OIL PUMP	13
CARBURETOR	17, 19	OIL TANK	65
CARTON PACKS	7	OIL PIPES	65
CENTRE STAND	43		
CHAINS	35	PISTONS	9
CHAINCASE	35	PROP STAND	43
CLUTCH	33	PUSH RODS	21, 23
CLUTCH LEVER ASSEMBLY	31		
COIL	75	REAR WHEEL	55
CONNECTING RODS	9	RECTIFIER	75
CONTACT BREAKER	25	REFLECTORS	57, 63
CONTROL CABLES	71	ROCKERS	23
CONTROL LEVERS	69		
CRANKCASE	11	SIDE PANEL	61
CRANKCASE UNDERSHIELD	41	SPARKING PLUG	75
CRANKSHAFT	9	SPEEDOMETER	81
CYLINDERS	21, 23	SPEEDOMETER GEARBOX	55
CYLINDER HEAD	21, 23	STEERING DAMPER	69
		STEERING RACES	43
		SUSPENSION UNITS	45
ENGINE PLATES	39	SWINGING ARM	45
ENGINE TORQUE STAY	39	SWITCHES	69, 77
EXHAUST PIPES	37, 41		
EXHAUST PIPE ADAPTOR	21, 23	TABLE OF STANDARD HARDWARE	81
		TACHOMETER	79
FENDERS	57	TACHOMETER GEARBOX	79
FLASHERS	77	TAIL LAMP	59
FOOTRESTS	41, 43	TAPPETS	21, 23
FRAME	43	TIMING GEARS	9
FRONT FORKS	47, 49	TOOLKIT	67
FRONT WHEEL	51, 53	TWIN SEAT	61
FUSE ASSEMBLY	67		
		VALVES	21, 23
GAS TANK	63	VALVE GUIDES	21, 23
GASKET SET	7		
GEARBOX	27, 29, 31	WIRING HARNESS	77
		ZENER DIODE	75

HOW TO USE THIS PARTS CATALOGUE

First consult the index on Page 3 for the parts or group of parts which you wish to locate. When you have located the parts make sure from the end columns that the part you have located does apply to your machine.

List the quantities required as single units; do not ask for "2 pairs" or "3 dozen".

In case of painted items always state the colour required. Painted parts are available only in the colours or alternatives specified for that model of that particular year.

<i>Model</i>	<i>Colour</i>
T100C T100R	} Cherry and Cold White

PLEASE NOTE

THROUGHOUT THIS LIST, ASSEMBLIES ARE PRINTED IN CAPITALS AND THE COMPONENTS INCLUDED IN THAT ASSEMBLY ARE INDENTED IN THE DESCRIPTION COLUMN, REVERTING TO THE ORIGINAL ALIGNMENT WHEN THE ASSEMBLY IS COMPLETE. TO ORDER THE COMPLETE ASSEMBLY IT IS NECESSARY ONLY TO QUOTE THE ASSEMBLY NUMBER. ANY COMPONENT PARTS LISTED MAY ALSO BE OBTAINED SEPARATELY IF REQUIRED.

SPECIAL WORKSHOP TOOLS

A COMPLETE LIST OF WORKSHOP TOOLS CAN BE MADE AVAILABLE BY EITHER CONTACTING YOUR DEALER OR APPLYING DIRECT TO THE TRIUMPH SERVICE DEPARTMENT. IN MOST CASES THESE TOOLS ARE VERY COSTLY AS THEY ARE MADE ENTIRELY FOR WORKSHOP USE, AND THEREFORE, IT IS NOT RECOMMENDED THAT THE PRIVATE OWNER PURCHASES THE TOOLS IN ORDER TO AID SERVICING THE MACHINE ONCE OR TWICE ONLY. IN THESE CIRCUMSTANCES IT IS FAR MORE ECONOMICAL TO GET IN TOUCH WITH A RECOGNISED DEALER.

UNIFIED THREAD FORM

NEW PARTS HAVING THREADED FIXINGS INTRODUCED IN THIS CATALOGUE HAVE THE UNIFIED FORM OF SCREW THREADS. THIS CHANGEOVER WILL BE CONTINUED AS AND WHEN NEW PARTS ARE INTRODUCED. EVEN WHERE PARTS ARE SIMILAR IN APPEARANCE NEW PART NUMBERS WILL BE ALLOCATED TO IDENTIFY THE UNIFIED THREADS. ALL NUTS, BOLTS AND STUDS HAVING THIS THREAD ARE IDENTIFIED BY MARKINGS. BOLTS HAVE A CIRCULAR RECESS IN THEIR HEADS, STUDS A CIRCULAR GROOVE ON THE END, AND NUTS HAVE INTERLOCKING CIRCLES ON THE SIDE.

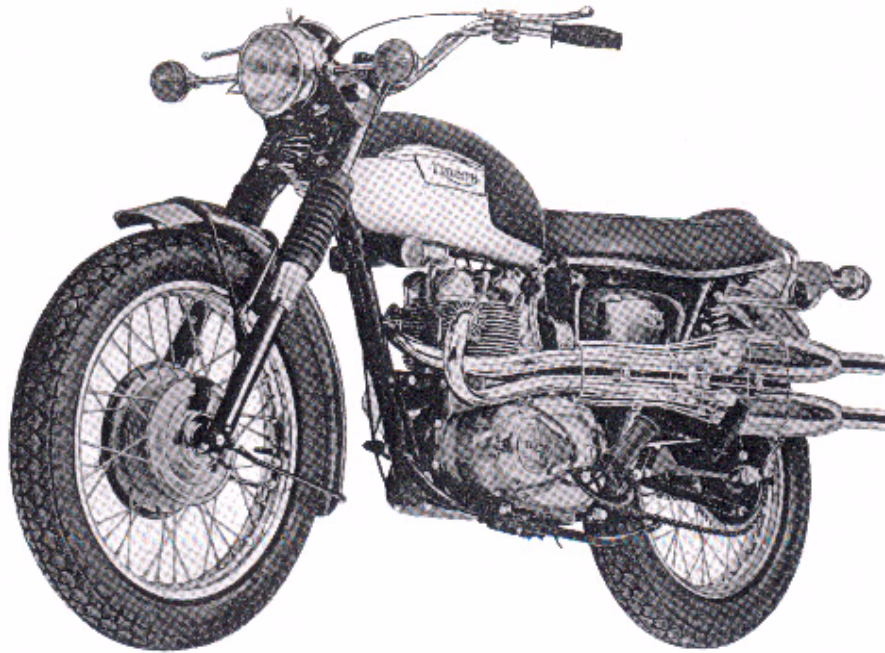

TIGER 100 (T100C) TECHNICAL DATA

Bore and Stroke		2.716 x 2.578 ins.
Capacity		30 cu. ins.
Compression Ratio		9 : 1
Spark Plugs		Champion N4
Carburetor		Amal Concentric
	Main Jet	170
	Needle Jet	.106
	Needle	Standard
	Throttle Valve	No. 4
Gearbox Sprocket		18 teeth
Chains	Front	$\frac{3}{8}$ in. Duplex x 78 links
	Rear	$\frac{3}{8}$ in. x $\frac{3}{8}$ in. x 102 links
Capacities	Gas Tank	2 $\frac{1}{4}$ U.S. galls.
	Oil Tank	6 U.S. pints
	Gearbox	2/3 pint (375 c.c.)
	Primary Chaincase (initial fill)	$\frac{1}{4}$ pint (150 c.c.)
	Front Forks (each leg)	$\frac{1}{2}$ pint (200 c.c.)
Brakes	Front and Rear, diameter	7 in. (17.18 cm.)
Tire Size	Front	3.50 x 19
	Rear	4.00 x 18

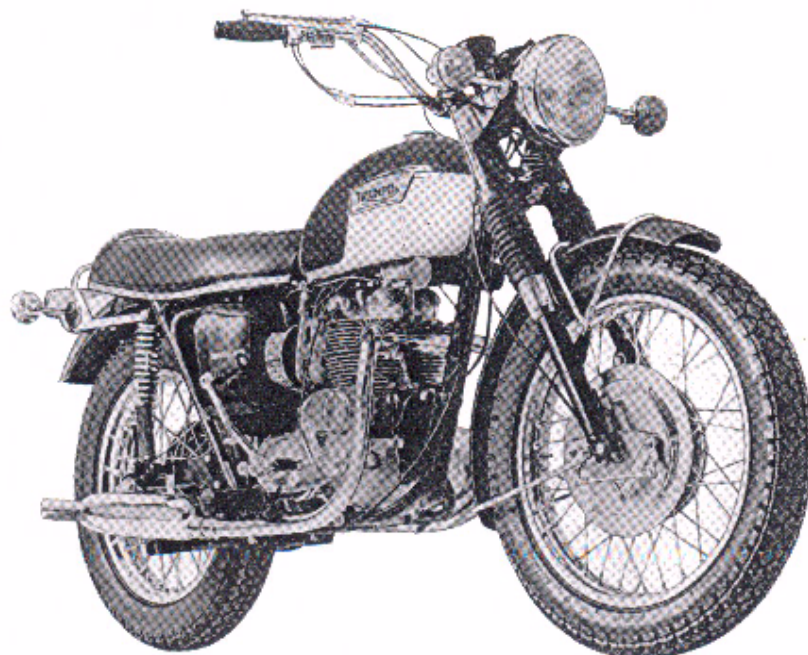

TIGER 100 (T100R) TECHNICAL DATA

Bore and Stroke		2.716 x 2.578 ins.
Capacity		30 cu. ins.
Compression Ratio		9 : 1
Spark Plugs		Champion N4
Carburetor		Amal Concentric
	Main Jet	150
	Needle Jet	.106
	Needle	Standard
	Throttle Valve	No. 3
Gearbox Sprocket		19 teeth
Chains	Front	$\frac{3}{8}$ in. Duplex x 78 links
	Rear	$\frac{5}{8}$ in. x $\frac{3}{8}$ in. x 103 links
Capacities	Gas Tank	2 $\frac{1}{4}$ U.S. Galls.
	Oil Tank	6 U.S. pints
	Gearbox	2/3 pint (375 c.c.)
	Primary Chaincase (Initial fill)	$\frac{1}{4}$ pint (150 c.c.)
	Front Forks (each leg)	$\frac{1}{3}$ pint (200 c.c.)
Brakes	Front, diameter	8 in. (20.32 cm.)
	Rear, diameter	7 in. (17.18 cm.)
Tire Size	Front	3.25 x 19
	Rear	400 x 18

CARTON PACK LIST

The following sub-assemblies are supplied in carton packs under the part number stated. The contents of these carton packs are preserved and will not deteriorate under adverse conditions.

PISTONS (c/w rings, gudgeon pins and circlips)

E.6906	7.0 : 1 C.R.	500 c.c.	Low grade fuel
E.6884	9 : 1 C.R.	500 c.c.	T100R, T100C
E.7603	7.5 : 1 C.R.	500 c.c.	Available

All piston assemblies are available in 0.010 in., 0.020 in., 0.040 in., oversizes (0.25 mm., 0.5 mm., 1.0 mm.).

BRAKE LININGS

C.P.38/AM2	2	NW243	Brake lining
	16	W129	Rivet
C.P.205	2	W1734	Brake lining
	16	W129	Rivet

VALVE SPRINGS (all models)

C.P.177	4	E5946	Inner valve spring
	4	E4011	Outer valve spring

STEERING HEAD RACES

C.P.156	2	H111	Cup
	1	H439	Cone
	1	H1018	Top cone
	40	S70-3	Ball

GASKET SETS

Decoke	99-1164
Overhaul	99-1167

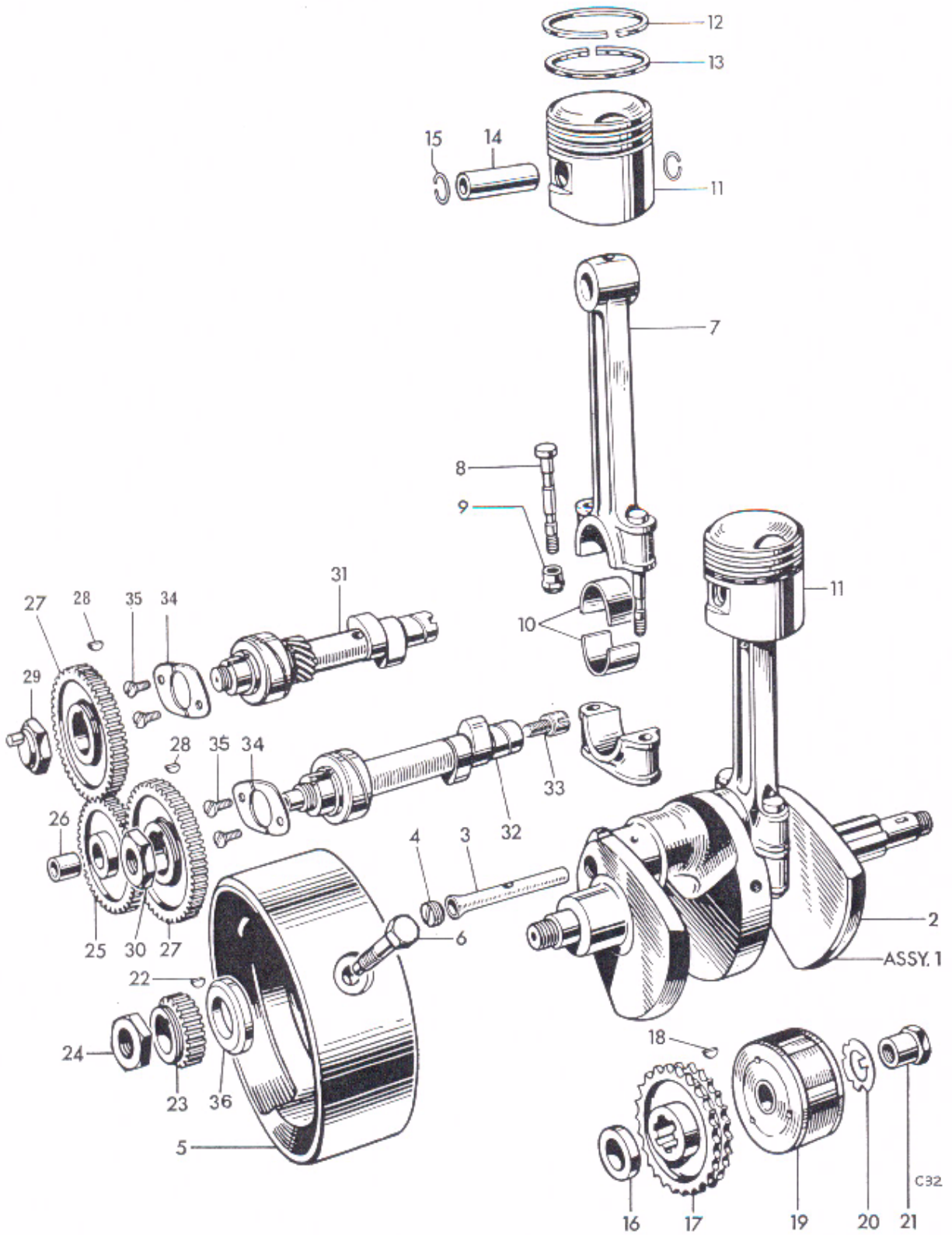

Fig. 1. CRANKSHAFT AND CONNECTING RODS

CRANKSHAFT AND CONNECTING RODS

1	E9489	CRANKSHAFT AND FLYWHEEL ASSEMBLY	1	
2	E9490	Crankshaft	1	
3	E3999	Oil tube	1	
4	E9492	Screwed plug	1	
5	E5870	Flywheel	1	
6	*S1913	Flywheel bolt (1 $\frac{1}{2}$ in. U.H.)	3	
7	E9915	CONNECTING ROD	2	
8	E9914	Connecting rod bolt	2	
9	S2016	Self-locking nut	2	
10	E3706	Big end bearing (available in —.010 and —.020 undersizes)	4	
11	E6884	PISTON COMPLETE C.R. 9.1	2	
12	E6893	Taper compression ring	4	
13	E6894	Oil control ring	2	
14	E6861	Gudgeon pin	2	
15	WE479	Circlip	4	
16	E12664	Spacer	1	
17	E3734	Engine sprocket, 26T Duplex	1	
18	E3851	Rotor key	1	
19	54213901	Rotor (99-0739)	1	
20	E3975	Tab washer	1	
21	S1915	Nut	1	
22	E1580	Key	1	
23	E1771	Timing pinion	1	
24	S1914	Nut	1	
25	E6160	INTERMEDIATE WHEEL	1	
26	E400	Bush	1	
27	E12717	Camshaft pinion	2	
28	E1558	Camshaft key	2	
29	E11007	Inlet camshaft nut	1	
30	E6523	Exhaust camshaft nut	1	
31	E11064	Inlet camshaft	1	
32	E9984	EXHAUST CAMSHAFT	1	T100R
32	E9983	EXHAUST CAMSHAFT	1	T100C
33	E9988	Tachometer drive plug	1	
34	E9502	Retaining plate	2	
35	S1929	Screw ($\frac{1}{2}$ in. U.H.)	4	
36	E9503	Clamping washer	1	
Not illus.	E8038	Shim (0.010")	As required	} up to 4
Not illus.	E12660	Shim (0.030")	As required	

*Use D524 Loctite sealant

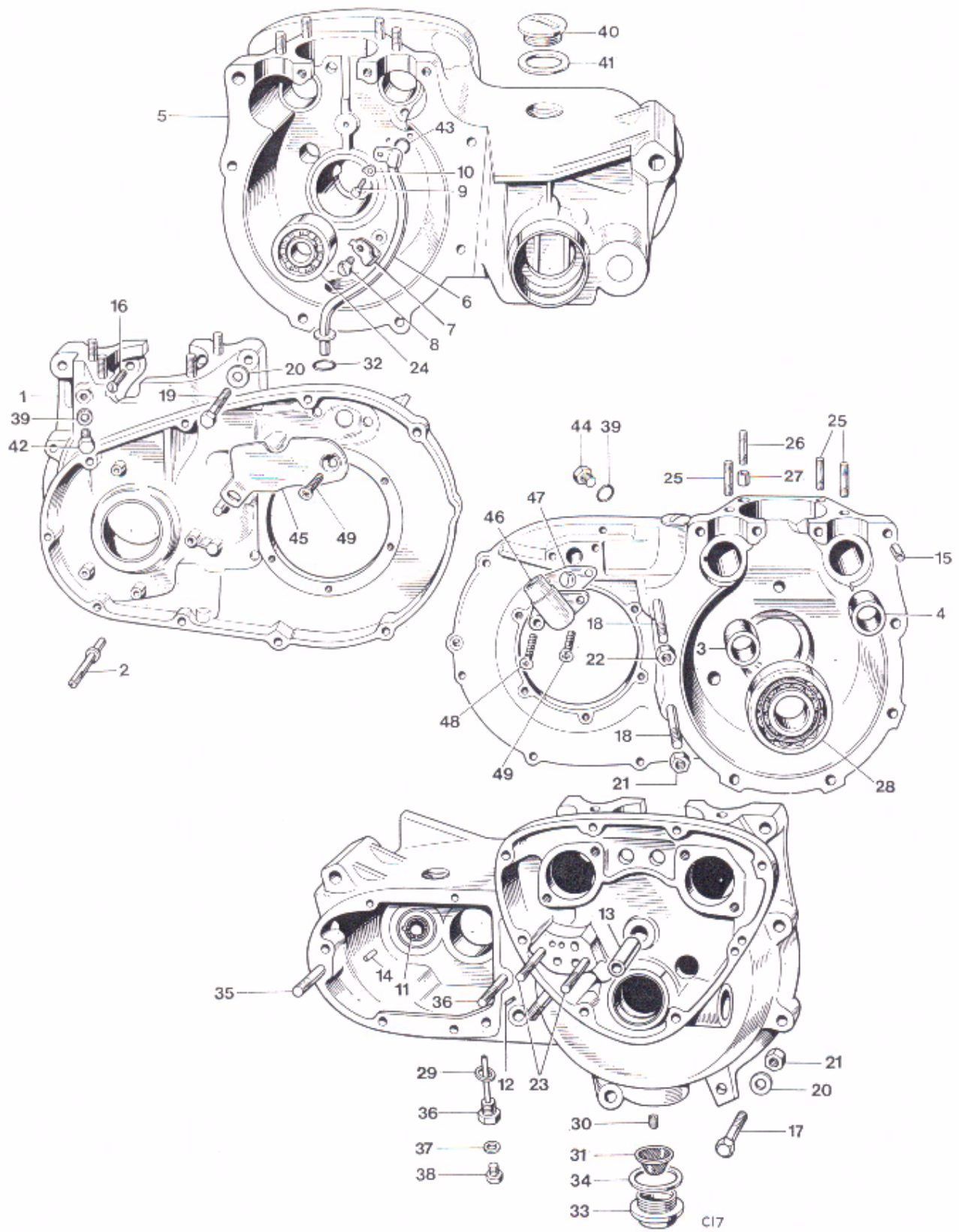

Fig. 2. CRANKCASE

Ref. No.	Part No.	DESCRIPTION	QUANTITY	REMARKS
CRANKCASE				
1	E11268	CRANKCASE DRIVE SIDE	1	
2	E4147	Pivot pin	1	
3	E3823	Camshaft bush	1	
4	E3823	Camshaft bush	1	
5	E11269	CRANKCASE TIMING SIDE	1	
6	E9496	Oil scavenge pipe	1	
7	E1509	Clip	1	
8	S1920	Screw	1	
9	14-6102	Bolt	1	
10	E7430	Tab washer	1	
11	T1606	Needle roller bearing	1	
12	E6386	Dowel at junction block	1	Ref. only
13	E375	Idler gear spindle	1	
14	T912	Peg (at thrust washer)	1	
15	E3716	Hollow dowel	2	
16	S1926	Screw ($3\frac{1}{2}$ in. U.H.)	2	
17	14-0225	Bolt	1	
18	S1925	Stud ($3\frac{3}{4}$ in. U.H.)	2	
19	S1919	Bolt	1	
20	S25-3	Plain washer	3	
21	14-1302	Nut	2	
22	S1852	Nut	1	
23	S1864	Oil pump stud ($1\frac{5}{8}$ in. O.A.)	2	
24	E9494	Right main bearing (ball journal)	1	
25	S1921	Cylinder base stud ($1\frac{1}{2}$ in. O.A.)	6	
26	S1922	Cylinder base stud ($1\frac{1}{8}$ in. O.A.)	2	
27	E8751	Dowel	2	
28	E9493	Left main bearing (roller journal)	1	
29	T1257	Washer	1	
30	E3724	Filter spring	1	
31	E3722	Filter	1	
32	E3723	Sealing washer	1	
33	E9501	Filter cap	1	
34	E1577	Joint washer	2	
35	S1927	Stud ($3\frac{1}{8}$ in. O.A.)	2	
36	T2167	Drain plug (with level tube)	1	
37	E2441	Fibre washer	1	
38	S543	Level plug	1	
39	E8896	Sealing washer	2	
40	T2166	Filler plug	2	
41	E8782	"O" ring	2	
42	S1871	Blanking plug (L.H. thread)	1	(Not T100R)
43	E7431	"O" ring	1	
44	S1872	Plug	1	
45	E11079	Cover plate	1	
46	E9335	Outlet stub-breather	1	
47	E11460	Joint washer	1	
48	E11075	Screw	1	
49	E11077	Screw	2	
Not illus.	E4707	Grommet, alternator leads	1	

1 OIL PUMP COMPLETE

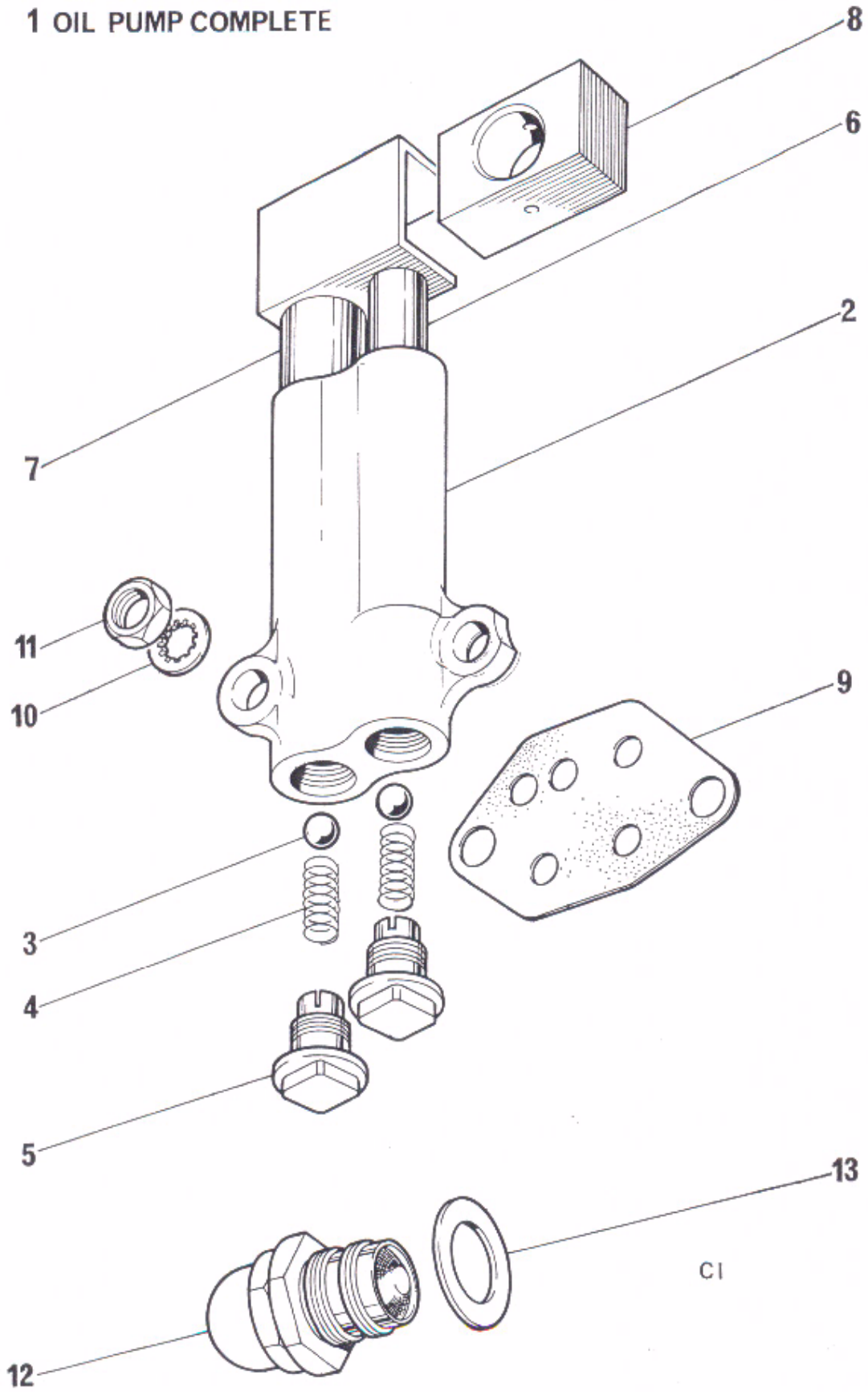

Fig. 3. OIL PUMP AND RELEASE VALVE

OIL PUMP AND RELEASE VALVE

1	E6928	OIL PUMP	1	
2	E6680	Pump body...	Reference only	
3	D2363	Valve ball	2	
4	E403	Valve spring	2	
5	E2360	Screwed plug	2	
6	GS153	Feed plunger	1	
7	E6681	Scavenge plunger	1	
8	E495	Drive block	1	
9	E11461	Joint washer	1	
10	E3887	Serrated washer	2	
11	S1906	Nut	2	
12	E6595	Oil release valve	1	
13	E1670	Joint washer	1	

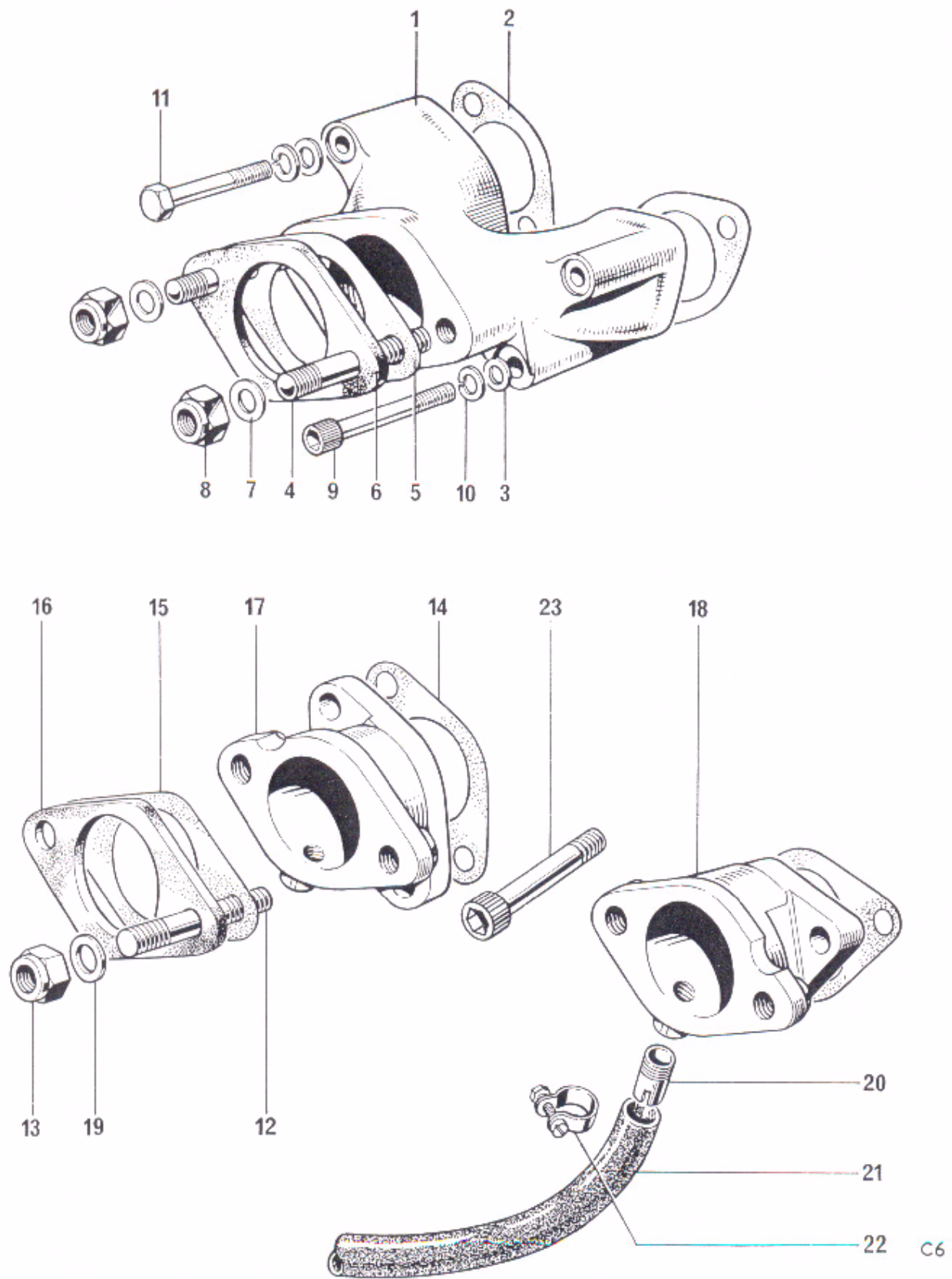

Fig. 4. INLET MANIFOLDS

INLET MANIFOLDS

Single Carburetor Model (T100C)

1	E7578	Inlet manifold	1	
2	E6772	Joint washer	2	
3	S25-3	Plain washer	4	
4	S582	Stud (1 $\frac{5}{16}$ in. O.A.)	2	
5	E11459	Joint washer	1	
6	E2968	Insulating block	1	
7	S25-3	Plain washer	2	
8	14-1302	Self locking nut	2	
9	14-7024	Socket head screw (2 in. U.H.)	2	
10	S648	Spring washer	4	
11	14-6115	Bolt	2	

Twin Carburetor Model (T100R)

12	S582	Stud (1 $\frac{5}{16}$ in. U.H.)	4	
13	14-1302	Self locking nut	4	
14	E6772	Joint washer, manifold	2	
15	E11459	Joint washer, insulating block	2	
16	E2968	Insulating block	2	
17	E7136	Left manifold	1	
18	E7137	Right manifold	1	
19	S25-3	Plain washer	4	
20	E6916	Connector	2	
21	E6958	Balance pipe	1	
22	E5473	Clip	2	
23	14-7019	Socket head screw ($\frac{7}{8}$ in. U.H.)	4	

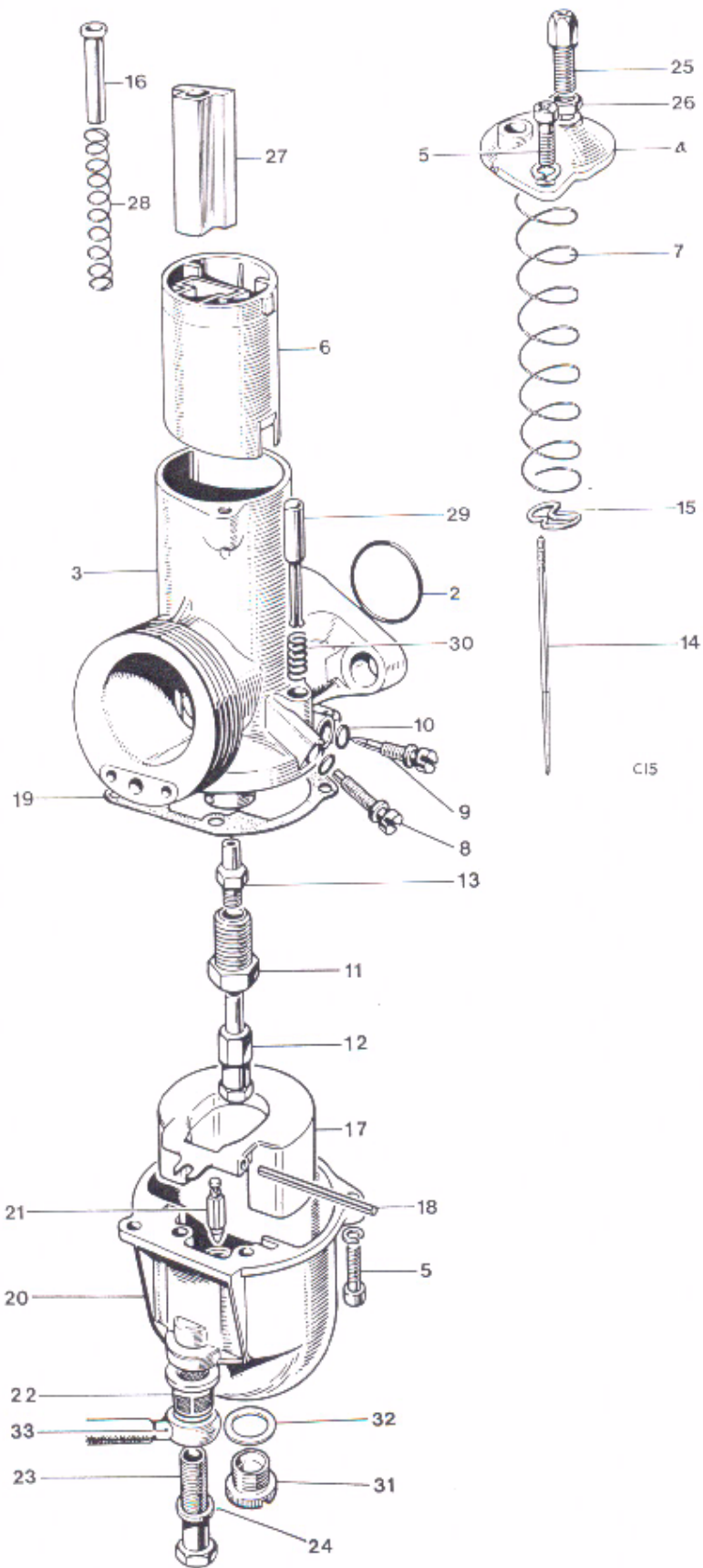

Fig. 5. CARBURETOR T100C

Ref. No.	Part No.	DESCRIPTION	QUANTITY	REMARKS
CARBURETOR, T100C				
1	D2455	CARBURETOR R626/52	1	
2	622/101	"O" ring seal (99-0522)	1	
3	Reference only	Mixing chamber R626/005	1	
4	622/097	Mixing chamber top (99-1049)	4	
5	622/086	Screw (99-0521)	1	
6	622/060	Throttle valve (4 cutaway) (99-1050)	1	
7	622/131	Throttle return spring (copper plated) (99-1033)	1	
8	622/077	Throttle stop screw (99-0516)	1	
9	622/076	Air adjusting screw (99-0515)	2	
10	622/082	"O" ring (99-0520)	1	
11	622/128	Jet holder (99-1034)	1	
12	376/100	Main jet (99-1132) size 170	1	
13	622/122	Needle jet (99-1035) size .106	1	
14	622/124	Needle (99-1036)	1	
15	622/067	Needle clip (99-0510)	1	
16	622/134	Air valve guide sleeve (99-1051)	1	
17	622/069	Float (99-0512)	1	
18	622/071	Float spindle (99-0513)	1	
19	622/073	Joint washer (99-0514)	1	
20	622/055	Float chamber (99-1154)	1	
21	622/068	Float needle (99-0511)	1	
22	376/093	Filter (99-0438)	1	
23	622/078	Banjo bolt (99-0517)	1	
24	13/163	Fibre washer (99-1124)	1	
25	4/035	Cable adjuster	Reference only	
26	5/077	Nut (99-0224)	1	
27	622/062	Air slide	Reference only	
28	622/129	Air slide spring (99-1038)	1	
29	622/089	Tickler pin	Reference only	
30	14/032	Spring	Reference only	
31	622/147	Drain plug (99-1152)	1	
32	622/151	Washer (99-1153)	1	
33	F9271	Petrol pipe	1	

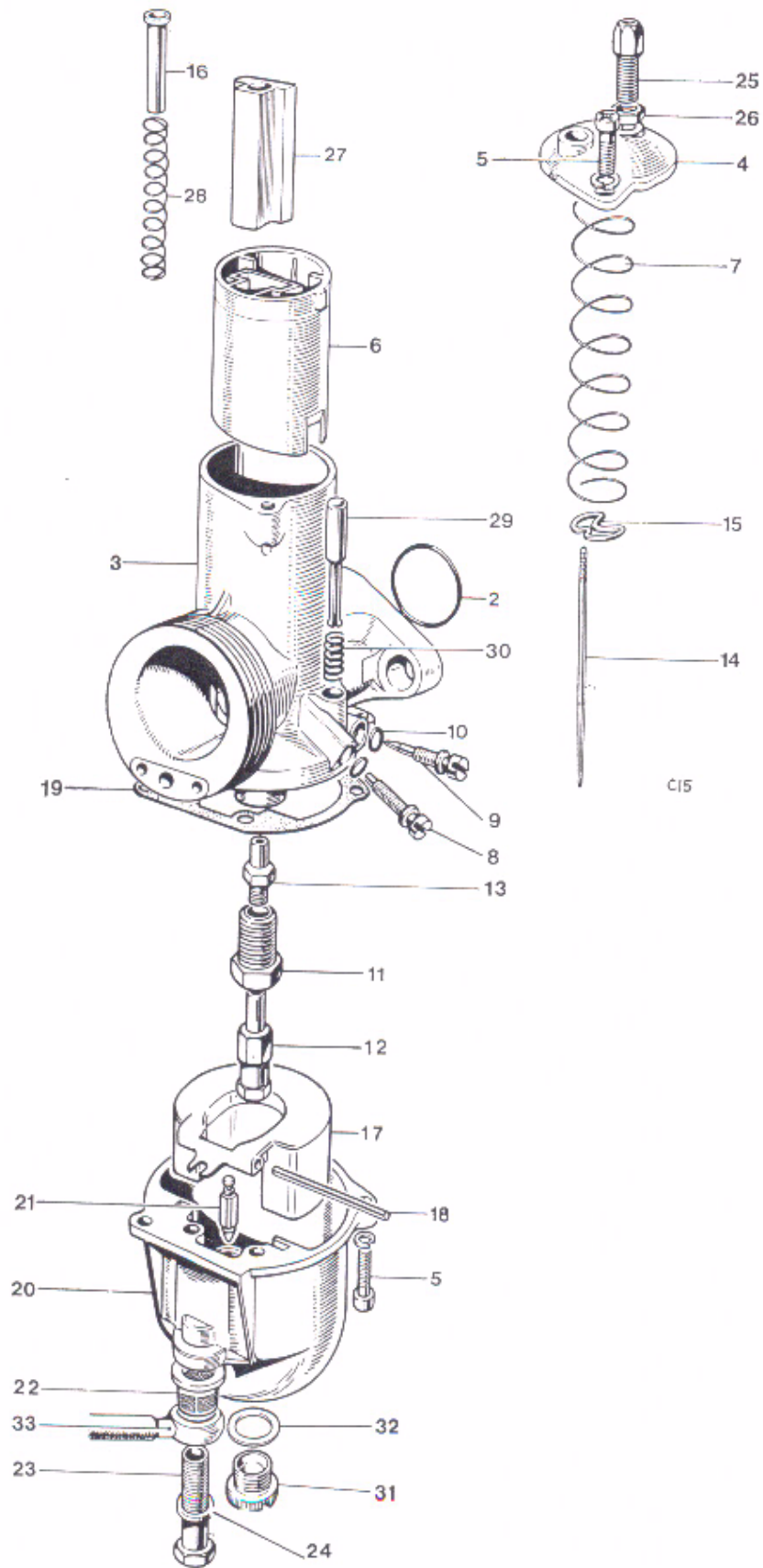

Fig. 6. CARBURETOR, T100R

CARBURETOR, T100R

1	D2453	CARBURETOR L626/54	1	Left
1	D2454	CARBURETOR R626/53	1	Right
2	622/101	"O" ring seal (99-0522)	1	} Each carburetor
3	Reference only	Mixing chamber	1	
4	622/097	Mixing chamber top (99-1049)	1	
5	622/086	Screw (99-0521)	4	
6	622/060	Throttle valve (3 cutaway) (99-1125)	1	
7	622/131	Throttle return spring (copper plated) (99-1033)	1	
8	622/077	Throttle stop screw (99-0516)	1	
9	622/076	Air adjusting screw (99-0515)	1	
10	622/082	"O" ring (99-0520)	2	
11	622/128	Jet holder (99-1034)	1	
12	376/100	Main jet (99-1131) size 150	1	
13	622/122	Needle jet (99-1035) size .106	1	
14	622/124	Needle (99-1036)	1	
15	622/067	Needle clip (99-0510)	1	
16	622/134	Air valve guide sleeve (99-1051)	1	
17	622/069	Float (99-0512)	1	
18	622/071	Float spindle (99-0513)	1	
19	622/073	Joint washer (99-0514)	1	
20	622/055	Float chamber (99-1154)	1	
21	622/068	Float needle (99-0511)	1	
22	376/093	Filter (99-0438)	1	
23	622/078	Banjo bolt (99-0517)	1	
24	13/163	Fibre washer (99-1124)	1	
25	4/035	Cable adjuster		Reference only
26	5/077	Nut (99-0224)	1	Each carburetor
27	622/062	Air slide		Reference only
28	622/129	Air slide spring (99-1038)	1	Each carburetor
29	622/089	Tickler pin		Reference only
30	14/032	Spring		Reference only
31	622/147	Drain plug (99-1152)	1	
32	622/151	Washer (99-1153)	1	
33	F9272	Petrol pipe	1	

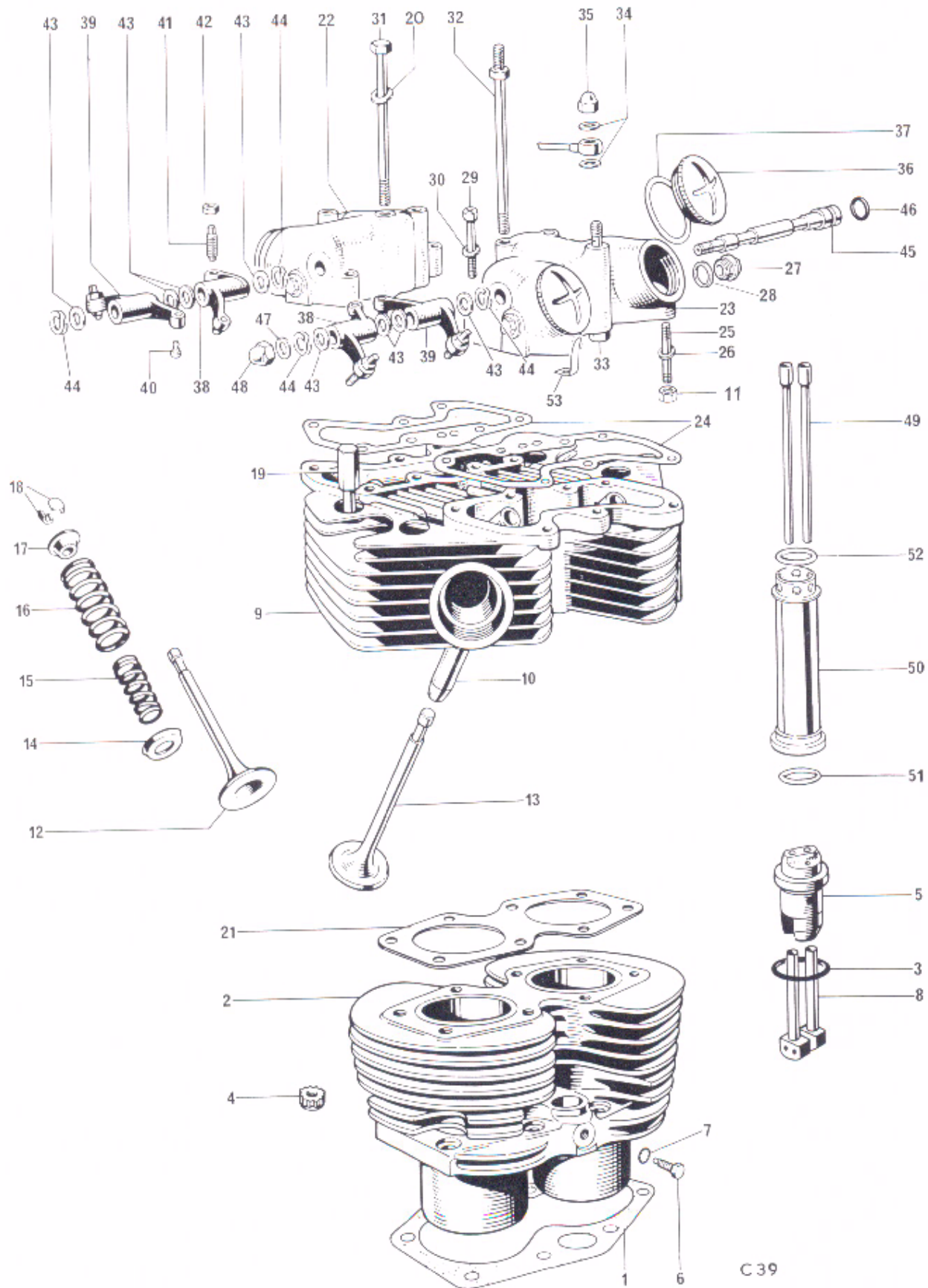

Fig. 7. CYLINDER BLOCK AND HEAD, T100C

CYLINDER BLOCK AND HEAD, T100C SINGLE CARBURETOR

1	E3798	Cylinder base gasket	1	
2	E9719	Cylinder block	1	
3	E7563	"O" ring	2	
4	S692	Nut (12 point)	8	
5	E9352	Tappet guide block	2	
6	H200	Tappet block screw ($\frac{7}{16}$ in. U.H.)	2	
7	E1612	Serrated washer	2	
8	E3753	Tappet	4	
9	E12644	CYLINDER HEAD c/w GUIDES	1	
10	E10229	Valve guide (cast iron)	4	
11	14-0301	Nut, rocker box	4	
12	E6853	Inlet valve	2	
13	E6854	Exhaust valve	2	
14	E6855	Bottom Cup	4	
15	E5946	Inner valve spring	4	
16	E4011	Outer valve spring	4	
17	E3742	Top collar	4	
18	99-0062	Split cotter	8	
19	E4456	Cylinder head bolt (2 25/32 in. U.H.)	4	
20	F2184	Plain washer	8	
21	E4675	Cylinder head gasket	1	
22	E12075	Inlet rocker box	1	
23	E12076	Exhaust rocker box	1	
24	E9511	Joint washer	2	
25	14-1401	Rocker box stud	4	
26	E3302	Washer	4	
27	E12079	Plug, rocker box	4	
28	E12080	Joint washer	4	
29	14-6609	Screw ($\frac{15}{16}$ in. U.H.)	4	
30	E3857	Plain washer	4	
31	E3794	Cylinder head bolt ($5\frac{7}{8}$ in. U.H.)	2	
32	E3795	Cylinder head torque stay bolt	2	
33	E3809	Oil feed bolt	2	
34	F1880	Copper washer	6	
35	H400	Domed nut	2	
36	E4610	Inspection cap	4	
37	E3751	Fibre washer	4	
38	E3749	ROCKER (right exhaust, left inlet)	2	
39	E3750	ROCKER (left exhaust, right inlet)	2	
40	E7651	Rocker ball pin	4	
41	E3223	Rocker adjusting pin	4	
42	GS662	Adjuster lock nut	4	
43	E2534	Thrust washer, $\frac{7}{16}$ in.	8	
44	E3224	Spring washer	4	
45	E3748	Rocker spindle	2	
46	D3548	Sealing rubber	2	
47	E1335	Copper washer	2	
48	E1435	Domed nut	2	
49	E4008	Push rod	4	
50	E12576	Cover tube	2	
51	E7310	"O" ring, push rod cover tube (bottom)	2	
52	E11283	"O" ring, push rod cover tube (top)	2	
53	E4671	Locking spring	4	

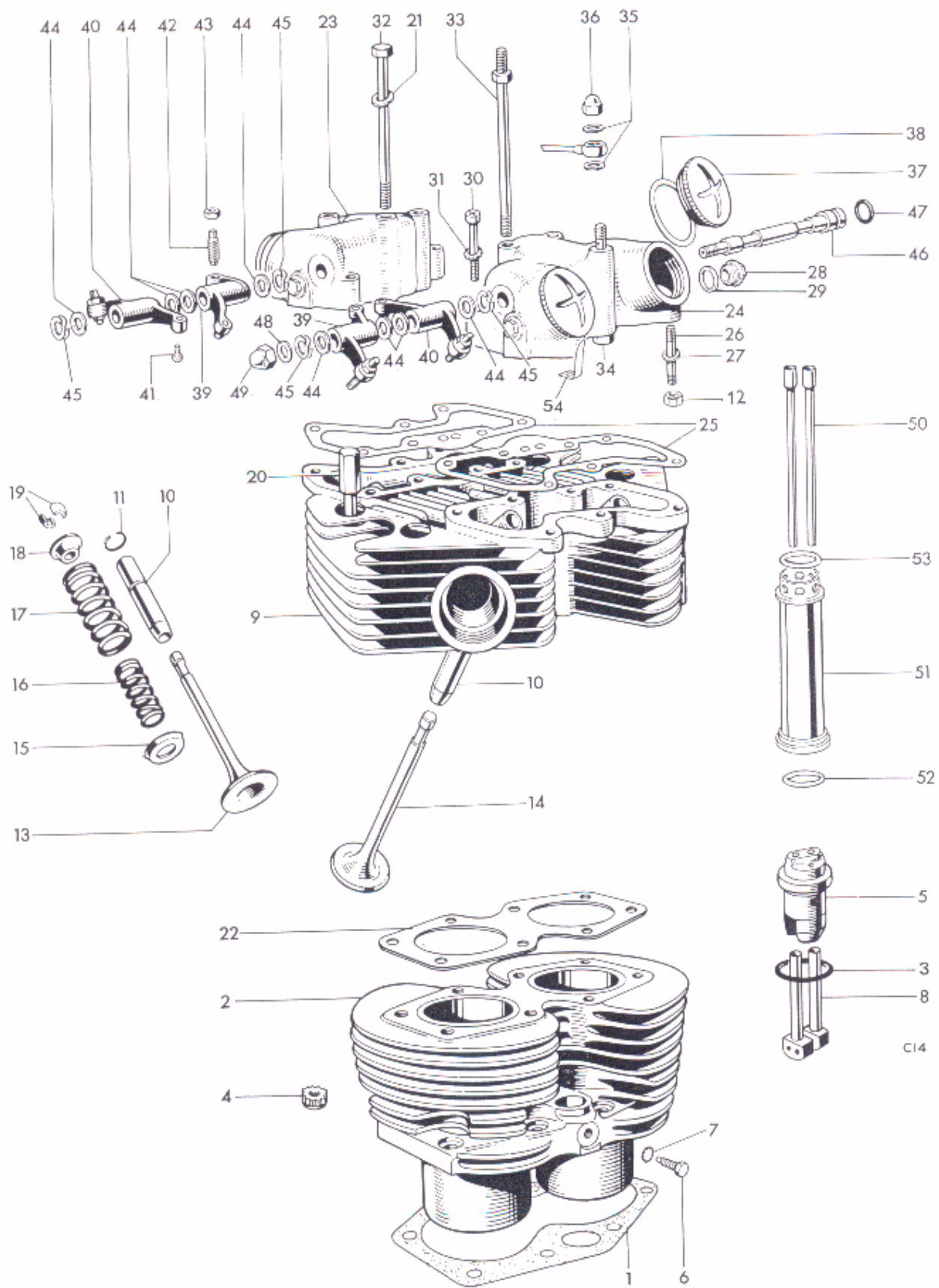
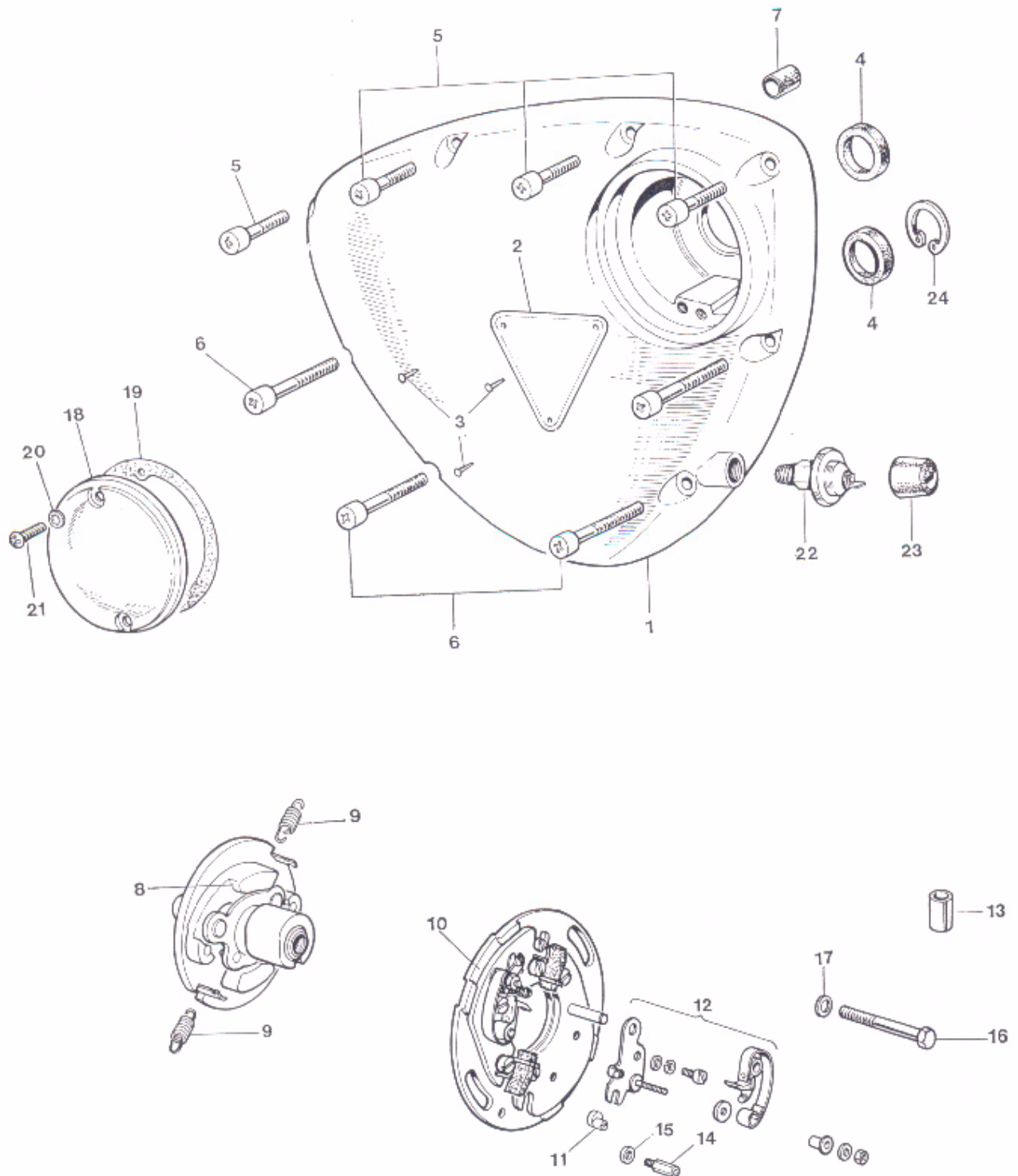

Fig. 7. CYLINDER BLOCK AND HEAD, T100R

CYLINDER BLOCK AND HEAD, T100R, TWIN CARBURETOR

1	E3798	Cylinder base gasket	1	
2	E9719	Cylinder block	1	
3	E7563	"O" ring	2	
4	S692	Nut (12 point)	8	
5	E9352	Tappet guide block	2	
6	H200	Tappet block screw ($\frac{7}{16}$ in. U.H.)	2	
7	E1612	Serrated washer	2	
8	E4040	Tappet, Racing type	4	
9	E12643	CYLINDER HEAD c/w GUIDES	1	
10	E6301	Valve guide	4	
11	E3209	Valve guide circlip	4	
12	14-0301	Nut, rocker box	4	
13	E6853	Inlet valve	2	
14	E6854	Exhaust valve	2	
15	E6855	Bottom cup	4	
16	E5946	Inner valve spring	4	
17	E4011	Outer valve spring	4	
18	E3742	Top collar	4	
19	99-0062	Split cotter	8	
20	E4456	Cylinder head bolt ($2\frac{25}{32}$ in. U.H.)	4	
21	F2184	Plain washer	8	
22	E4675	Cylinder head gasket	1	
23	E12075	Inlet rocker box	1	
24	E12076	Exhaust rocker box	1	
25	E9511	Joint washer	2	
26	14-1401	Rocker box stud	4	
27	E3302	Washer	4	
28	E12079	Plug, rocker box	4	
29	E12080	Joint washer	4	
30	14-6609	Screw ($1\frac{1}{4}$ in. U.H.)	4	
31	E3857	Plain washer	4	
32	E3794	Cylinder head bolt ($5\frac{7}{16}$ in. U.H.)	2	
33	E3795	Cylinder head torque stay bolt	2	
34	E3809	Oil feed bolt	2	
35	F1880	Copper washer	6	
36	H400	Domed nut	2	
37	E4610	Inspection cap	4	
38	E3751	Fibre washer	4	
39	E3749	ROCKER (right exhaust, left inlet)	2	
40	E3750	ROCKER (left exhaust, right inlet)	2	
41	E7651	Rocker ball pin	4	
42	E3223	Rocker adjusting pin	4	
43	GS662	Adjuster lock nut	4	
44	E2534	Thrust washer, $\frac{7}{16}$ in.	6	
45	E3224	Spring washer	2	
46	E3748	Rocker spindle	2	
47	D3548	"O" ring	2	
48	E1335	Copper washer	2	
49	E1435	Domed nut	2	
50	E4008	Push rod	4	
51	E12576	Cover tube	2	
52	E7310	"O" ring, push rod cover tube (bottom)	2	
53	E11283	"O" ring, push rod cover tube (top)	2	
54	E4671	Locking spring	4	



C21

Fig. 8. TIMING COVER AND CONTACT BREAKER

TIMING COVER AND CONTACT BREAKER

1	E9250	Timing cover	1	
2	E4016	Patent plate	1	
3	D208-5	Hammer-drive screw	3	
4	E4568	Oil seal	2	
5	14-6607	Screw ($\frac{7}{8}$ in. U.H.)	4	
6	S1916	Screw ($1\frac{1}{8}$ in. U.H.)	4	
7	T989	Hollow dowel	2	
8	54419340	AUTO-ADVANCE UNIT (99-0771)	1	
9	54415642	Spring set (99-0757)	2	
10	54419097	CONTACT BREAKER PLATE ASSEMBLY (99-0768)	1	
11	54419220	Pin adjustment (99-0769)	2	
12	54419827	Contact set (99-0772)	2	
13	E4707	Rubber grommet	1	
14	E7680	Pillar bolt	2	
15	E6559	Washer	2	
16	14-0208	Bolt	1	
17	S25-43	Washer	1	
18	E8737	Cover	1	
19	E11462	Joint washer	1	
20	GS299	Serrated washer	2	
21	E7354	Screw	2	
22	D2133	Oil pressure switch	1	
23	D2045	Cover pressure switch	1	
24	E4569	Circlip	1	
Not illus.	E4849	Dowel pin, auto advance to camshaft	1	
Not illus.	D2138	Timing label for C.B. cover	1	
Not illus.	E9526	Blanking plug (to replace oil pressure switch)	Available	

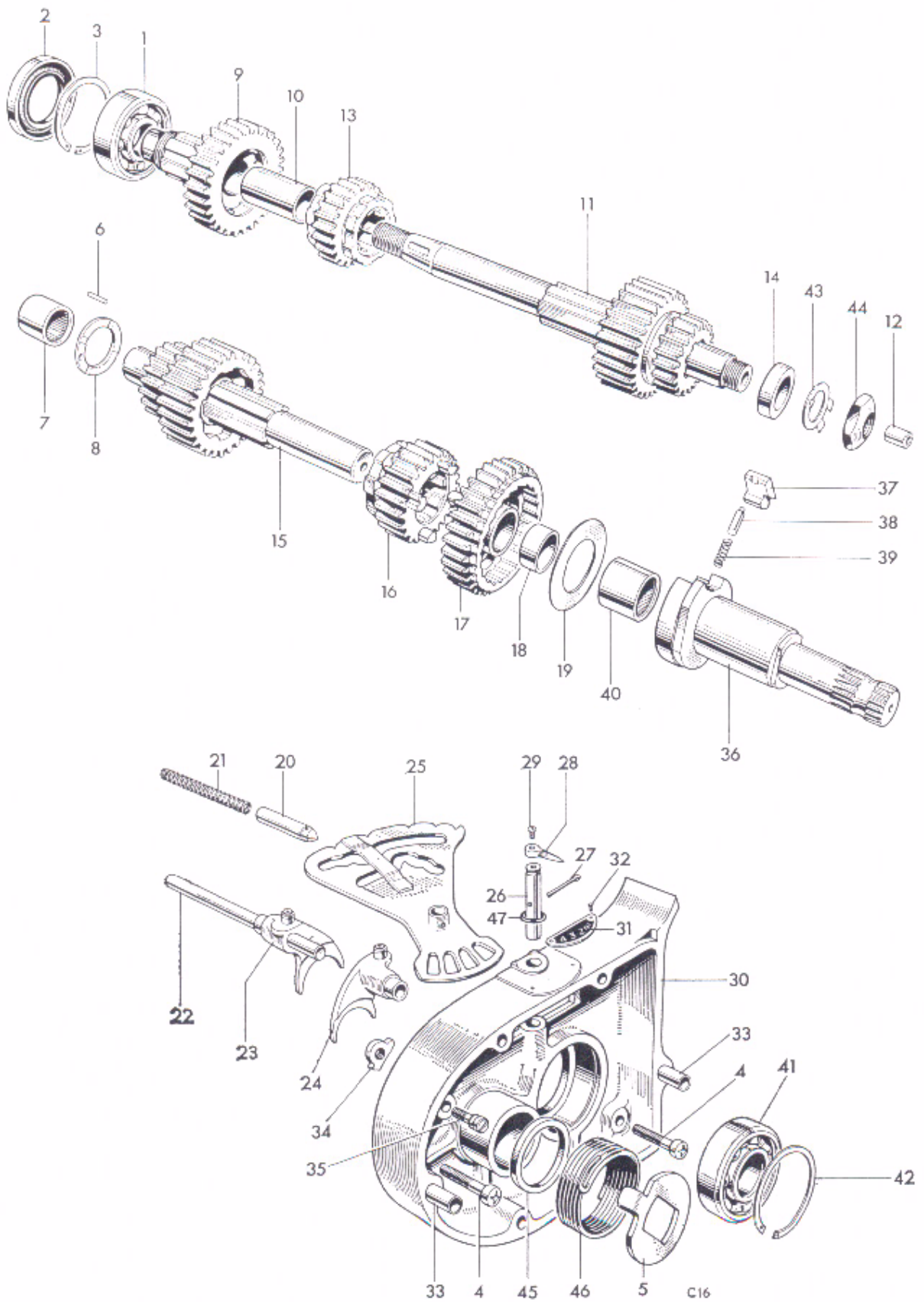

Fig. 9. GEARBOX SHAFTS, BEARINGS AND INNER COVER

GEARBOX SHAFTS, BEARINGS AND INNER COVER

1	T665	High gear bearing (ball journal)	1	
2	T1478	Oil seal	1	
3	W680	Circlip	1	
4	14-6608	Screw	2	
5	T1422	Return spring plate	1	
6	T912	Peg	1	
7	T1606	Layshaft bearing	1	
8	T1607	Thrust washer	1	
9	T3991	MAINSHAFT HIGH GEAR (22T)	1	} T100R and West Coast T100C
10	T4007	High gear bush	1	
11	T4039	MAINSHAFT c/w THIRD AND LOW GEARS (16/24T)	1	
12	T1391	Clutch rod bush	1	
13	T3994	Mainshaft second gear (21T)	1	
14	T1411	Mainshaft distance piece	1	
15	T4041	Layshaft c/w second and high gears (15/23T)	1	
16	T3997	Layshaft third gear (20T)	1	
17	T3999	LAYSHAFT LOW GEAR (27T)	1	
18	T1393	Low gear bush	1	
19	T1426	Pawl retaining disc	1	
20	T3660	Camplate index plunger	1	
21	T3661	Index plunger spring	1	
22	T1457	Selector fork spindle	1	
23	T1480	Mainshaft selector fork	1	
24	T1481	Layshaft selector fork	1	
25	T4218	Gear selector camplate	1	
26	T1418	Camplate spindle	1	
27	—	Split pin ($\frac{1}{8}$ in. x $\frac{3}{4}$ in.)		Reference only
28	T1416	Gear indicator pointer	1	
29	H688	Screw ($\frac{5}{16}$ in. U.H.)	1	
30	T4300	INNER COVER	1	
31	T1417	Gear indicator plate		Reference only
32	D208-5	Indicator plate rivet		Reference only
33	T1440	Hollow dowel	2	
34	T1157	Kickstarter stop plate	1	
35	T1390	Stop plate anchor screw	1	
36	T1981	KICKSTARTER SPINDLE	1	
37	T1431	Kickstarter pawl	1	
38	T1282	Plunger	1	
39	T1161	Plunger spring	1	
40	T1897	Needle roller bearing	1	
41	T1469	Mainshaft bearing (Ball journal)	1	
42	T4113	Circlip	1	
43	T732	Tab washer	1	
44	S594	Mainshaft nut	1	
45	T1464	Distance piece	1	
46	T1441	Kickstarter return spring	1	
47	E4803	"O" ring	1	

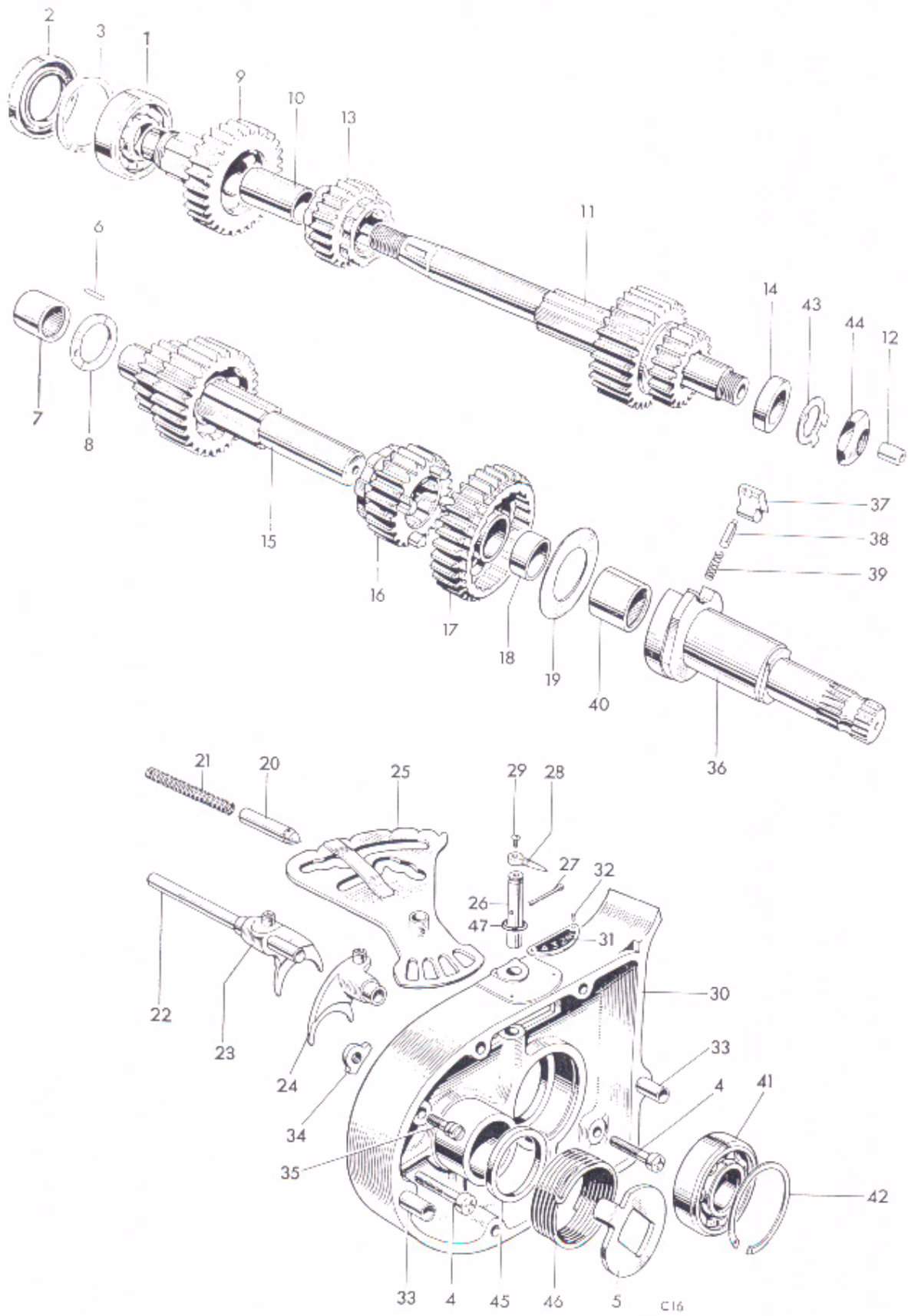

Fig. 11. GEARBOX SHAFTS, BEARINGS AND INNER COVER

WIDE RATIO GEARS

Standard on East Coast T100C

9	T4029	MAINSHAFT HIGH GEAR (23T)	1	
11	T4040	MAINSHAFT c/w THIRD AND LOW GEAR (15/24T) ...	1	
13	T4031	Mainshaft second gear (20T)	1	
15	T4042	Layshaft c/w second and high gear (14/24T) ...	1	
16	T3997	Layshaft third gear (20T)	1	
17	T4033	LAYSHAFT LOW GEAR (29T)	1	

CLOSE RATIO GEARS

(Available if required)

9	T4419	MAINSHAFT HIGH GEAR (20T)	1	
11	T4409	MAINSHAFT c/w THIRD AND LOW GEAR (16/22T) ...	1	
13	T4411	Mainshaft second gear (20T)	1	
15	T4416	Layshaft c/w second and high gear (17/23T) ...	1	
16	T4414	Layshaft third gear (21T)	1	
17	T3999	LAYSHAFT LOW GEAR (27T)	1	

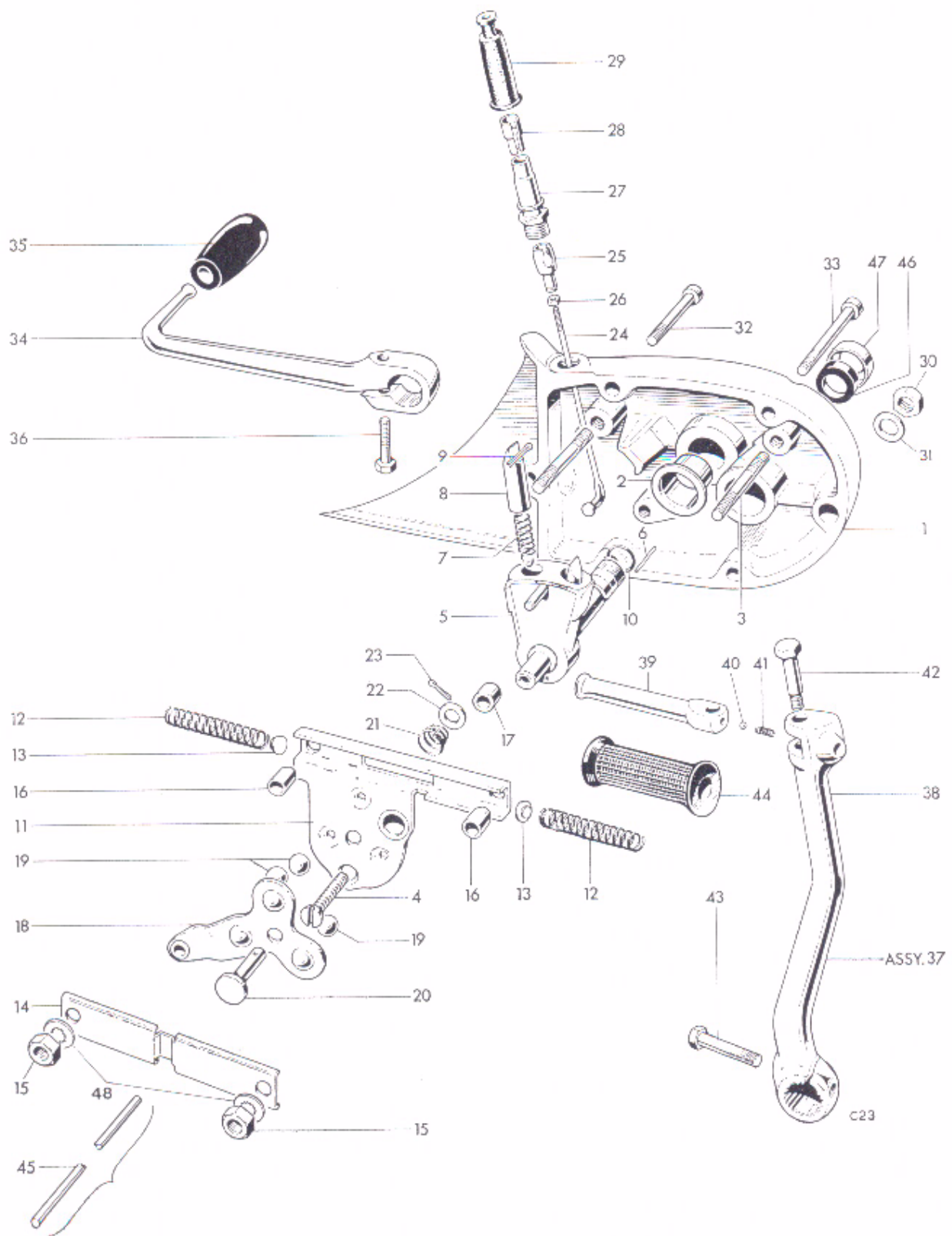

Fig. 12. GEARBOX OUTER COVER AND LEVERS

GEARBOX OUTER COVER AND LEVERS

1	T3755	GEARBOX OUTER COVER...	1	
2	T1395	Gearchange spindle bush...	1	
3	S1928	Stud ($1\frac{5}{16}$ in. O.A.)	2	
4	14-6505	Screw	1	
5	T1942	GEARCHANGE QUADRANT	1	
6	T1474	Spring retaining pin	2	
7	T1436	Plunger spring	2	
8	T1396	Selector plunger	2	
9	—	Split pin ($\frac{5}{64}$ in. \times $\frac{3}{4}$ in.)		Reference only
10	T2697	Sealing ring	1	
11	T1871	Return spring housing	1	
12	T1877	Return spring	2	
13	T1878	Thrust button	2	
14	T1977	Cover	1	
15	S1877	Nut	2	
16	T1876	Distance piece	2	
17	T1874	Distance piece	1	
18	T4439	Clutch lever	1	
19	D2368	Ball, $\frac{3}{8}$ in. diam.	3	
20	T1710	Shaft	1	
21	T1712	Spring	1	
22	GS127	Plain washer	1	
23	—	Split pin ($\frac{5}{64}$ in. \times $\frac{1}{2}$ in.)		Reference only
24	T1945	Spoke	1	
25	T1946	Connector	1	
26	T1937	Nut	1	
27	T3784	Abutment	1	
28	T2062	Adaptor, short		As required
28	T2063	Adaptor, long (For cable with short outer)		As required
29	T1646	Rubber cover	1	
30	14-1302	Nut	2	
31	S25-3	Plain washer	2	
32	S1918	Screw	2	
33	S1917	Screw	2	
34	T1435	Gearchange lever	1	
35	T2450	Pedal rubber	1	
36	W932	Bolt (1 in. U.H.)	1	
37	T3797	KICKSTARTER LEVER COMPLETE	1	
38	T3742	Kickstarter crank	1	
39	T1272	Kickstarter pedal	1	
40	D2364	Steel ball ($\frac{1}{4}$ in. diam.)	1	
41	T1167	Index spring	1	
42	S541	Pivot bolt	1	
43	S644	Clamp bolt ($1\frac{5}{16}$ in. U.H.)	1	
44	T2330	Pedal rubber	1	
45	T1970	Clutch operating rod	1	
46	T2239	Oil seal	1	
47	T2238	Oil seal cover	1	
48	E1612	Serrated washer	2	

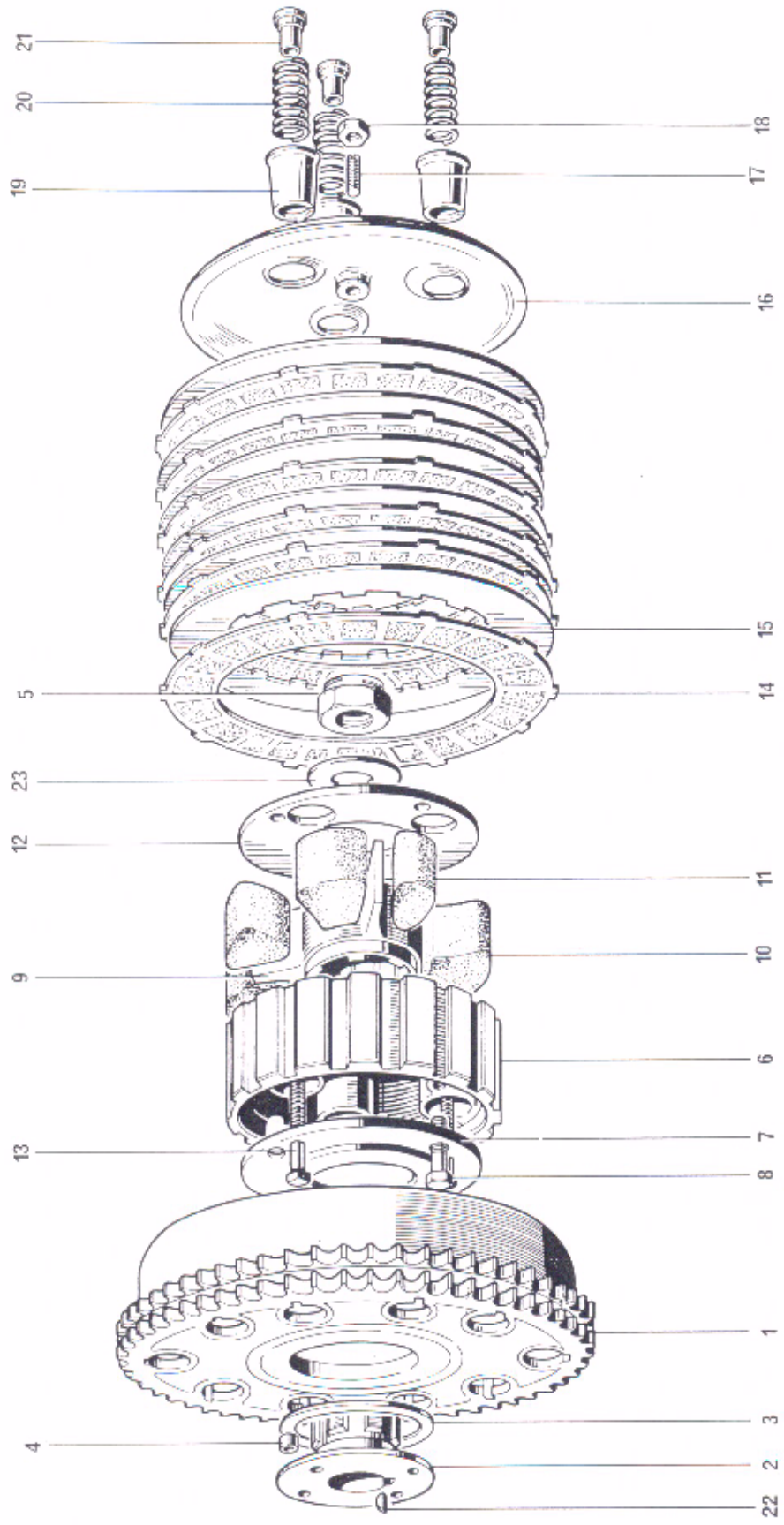

Fig. 13. CLUTCH

CLUTCH

1	T1570	Sprocket and housing ...	1	
2	T3930	Hub ...	1	
3	T3931	Thrust washer ...	1	
4	T394	Roller ...	20	
5	S586	Nut ...	1	
6	T4438	Centre (Shock absorber body)	1	
7	T4436	Inner plate ...	1	
8	S644	Bolt ...	3	
9	T2538	Shock absorber spider	1	
10	T1722	Drive rubber (large) ...	3	
11	T1723	Rebound rubber (small)	3	
12	T4437	Outer plate ...	1	
13	T423A	Screwed pin ($1\frac{27}{32}$ in. U.H.)	3	
14	T1362	Driving plate (bonded)	6	
15	T1363	Driven plate (plain) ...	6	
16	T2156	Pressure plate	1	
17	T2159	Adjuster pin ...	1	
18	14-0403	Nut ...	1	
19	T1931	Spring cup ...	3	
20	T1560	Spring ...	3	
21	T2526	Nut ...	3	
22	S66-1	Key ...	1	
23	T2279	Washer ...	1	

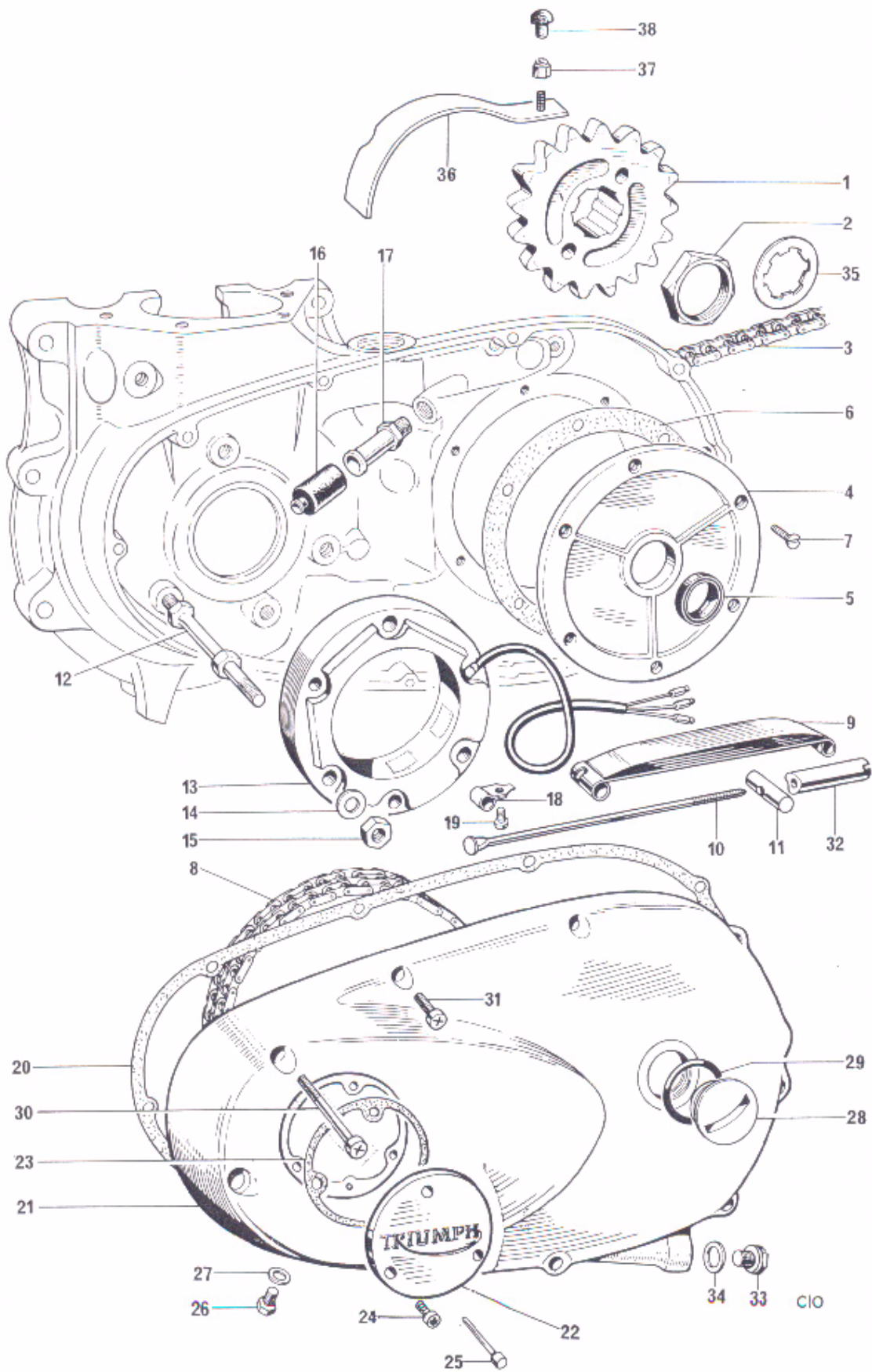

Fig. 14. CHAINCASE AND CHAINS

CHAINCASE AND CHAINS

1	T1476/18	Gearbox sprocket (18 teeth) ...	1	
1	T1476/19	Gearbox sprocket (19 teeth) ...	Available	
1	T1569	Gearbox sprocket (20 teeth) ...	Available	
2	T2536	Gearbox sprocket nut	1	
3	D444	Rear chain, $\frac{5}{8}$ in. x $\frac{3}{8}$ in. x 102L	1	
4	E7037	Cover plate	1	
5	E7565	Oil seal	1	
6	E11419	Joint washer	1	
7	E3821	Countersunk screw ($\frac{5}{16}$ in. U.H.)	6	
8	D358	Primary chain, $\frac{3}{8}$ in. Duplex 78L	1	
9	E6283	Chain tensioner blade	1	
10	E4152	Tie rod	1	
11	E4148	Trunnion	1	
12	E9495	Stud ($3\frac{5}{16}$ in. O.A.)	3	
13	47205	Stator, RM 21 (99-1006)	1	
14	S25-3	Plain washer	3	
15	14-0702	Nut	3	
16	E4144	Rubber grommet	1	
17	E9360	Sleeve nut	1	
18	E1509	Clip	1	
19	S1920	Setscrew	1	
20	E11456	Joint washer	1	
21	E9249	Chaincase	1	
22	T2440	Rotor cover	1	
23	E11457	Joint washer	1	
24	F4129	Screw	3	
25	T2537	Ignition pointer...	1	
26	14-6101	Level plug	1	
27	E2441	Copper washer	2	
28	T2166	Filler plug	1	
29	E8782	"O" ring	1	
30	S1878	Screw ($2\frac{3}{4}$ in. U.H.)	3	
31	14-6609	Screw	7	
32	E9703	Adjuster sleeve nut	1	
33	T2259	Drain plug	1	
34	T1738	Fibre washer	1	
35	T2056	Tab washer	1	
36	E7571	Crankcase protector	1	
37	14-1301	Self-locking nut	1	
Not illus.	E11373	Grommet	1	

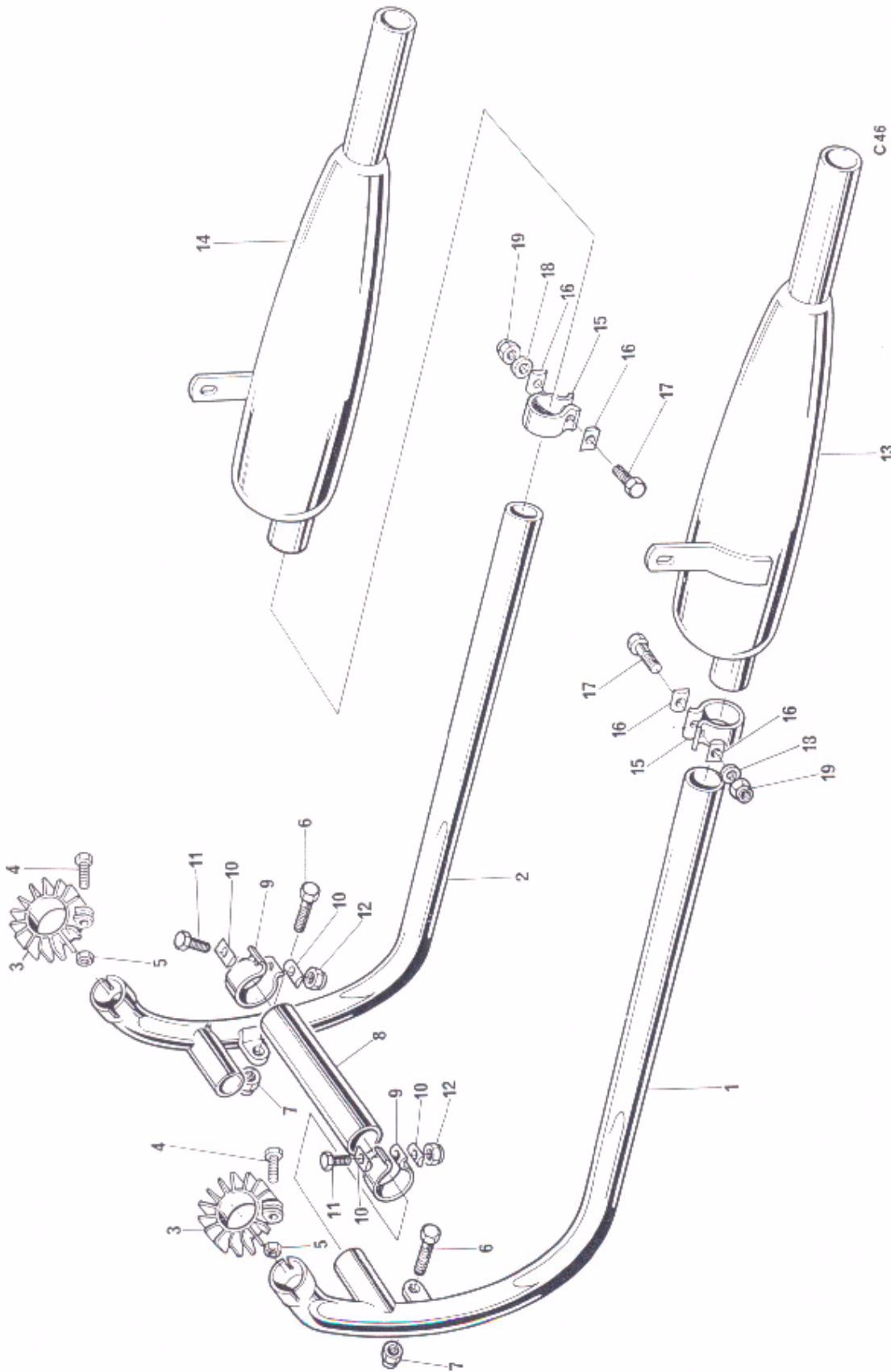

Fig. 15. EXHAUST SYSTEM

EXHAUST SYSTEM (T100R)

1	E12628	Exhaust pipe—L.H.	1	
2	E12629	Exhaust pipe—R.H.	1	
3	E12466	Finned clip	2	
4	F8977	Bolt	} Exhaust pipes to cylinder head	2	
5	F8978	Nut		2	
6	14-0102	Bolt	} Exhaust pipes to brackets	2	
7	14-1301	Nut		2	
8	E9888	Coupling pipe	1	
9	E7512	Clip	} Coupling pipe	2	
10	E3768	"D" washer		4	
11	14-0217	Bolt		2	
12	14-1302	Nut		2	
13	E12017	Muffler—D.S.	1	
14	E12018	Muffler—T.S.	1	
15	E2271	Clip	} Mufflers to exhaust pipes	2	
16	E3768	"D" washer		4	
17	14-0219	Bolt		2	
18	S25-3	Washer		2	
19	14-1202	Nut	2		

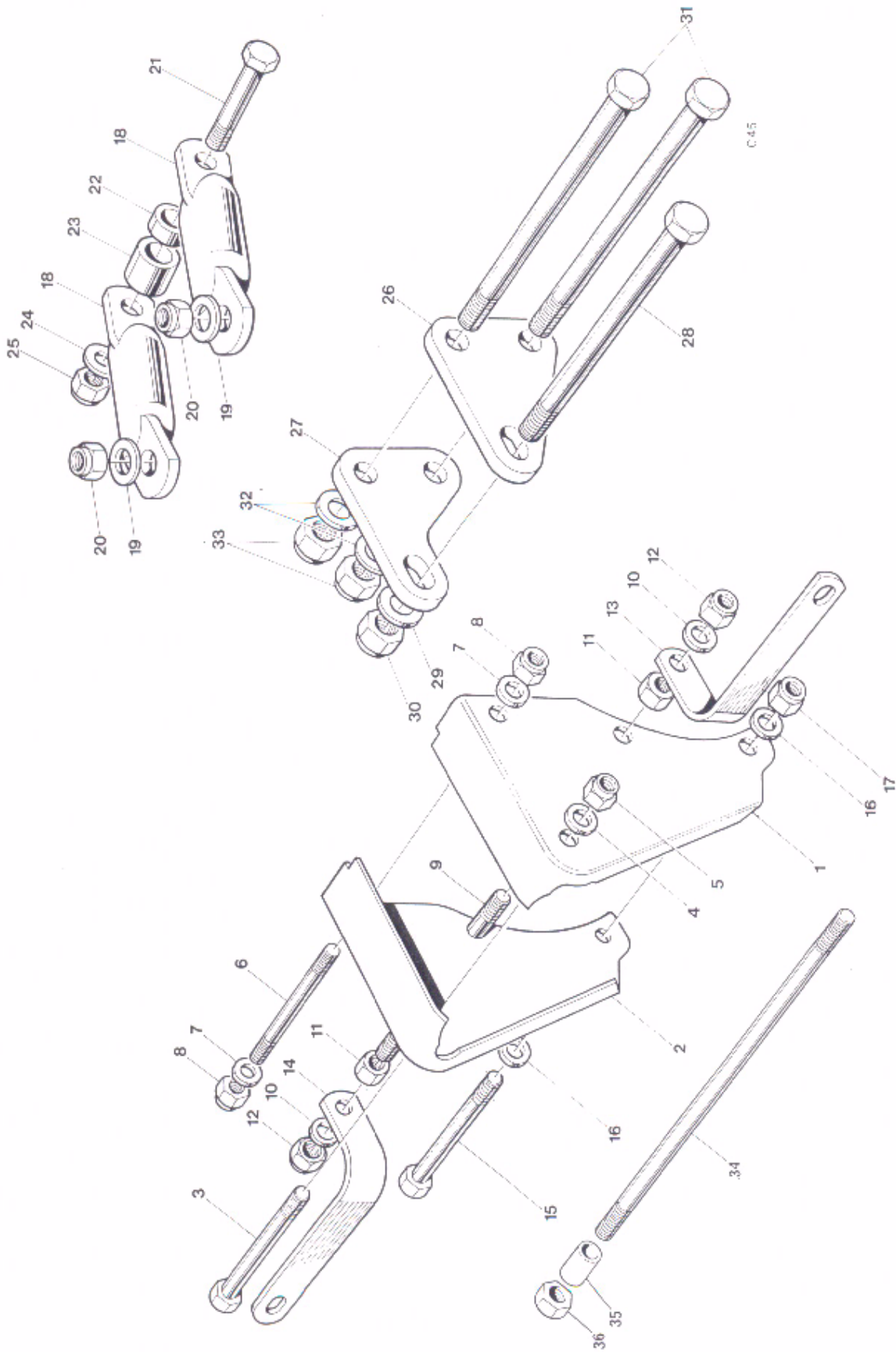

Fig. 16. MOTOR FITTINGS

MOTOR FITTINGS

Ref. No.	Part No.	Description	Quantity	Remarks
1	F7333	Front motor plate—D.S.	1	
2	F7334	Front motor plate—T.S.	1	
3	14-0239	Bolt	1	
4	S25-2	Washer	1	
5	14-1303	Nut (Cleveloc)	1	
6	S2006	Stud (3 $\frac{1}{8}$ in. O.A.)	1	
7	S25-3	Washer	2	
8	14-1302	Nut (Cleveloc)	2	
9	S2083	Stud (4 $\frac{1}{4}$ in. O.A.)	1	(Not T100C)
10	S25-3	Washer	2	
11	14-0302	Nut (plain)	2	(Not T100C)
12	14-1302	Nut (Cleveloc)	2	(Not T100C)
13	E7641	Exhaust bracket—D.S.	1	
14	E7642	Exhaust bracket—T.S.	1	
15	14-0225	Bolt	1	(2 T100C)
16	S25-3	Washer	2	
17	14-1302	Nut (Cleveloc)	1	(2 T100C)
18	E4778	Torque stay	2	
19	S26-1	Washer	2	
20	S1-52	Nut	2	
21	14-0220	Bolt	1	
22	E7119	Distance piece—D.S.	1	
23	E3434	Distance piece—T.S.	1	
24	S25-3	Washer	1	
25	14-1302	Nut (Cleveloc)	1	
26	F4229	Rear motor plate—D.S.	1	
27	F4230	Rear motor plate—T.S.	1	
28	14-0242	Bolt	1	
29	S25-2	Washer	1	
30	14-1303	Nut (Cleveloc)	1	
31	14-0228	Bolt	2	
32	S25-3	Washer	2	
33	14-1302	Nut (Cleveloc)	2	
34	S2004	Stud	1	
35	F5532	Distance piece	2	
36	14-1303	Nut	2	

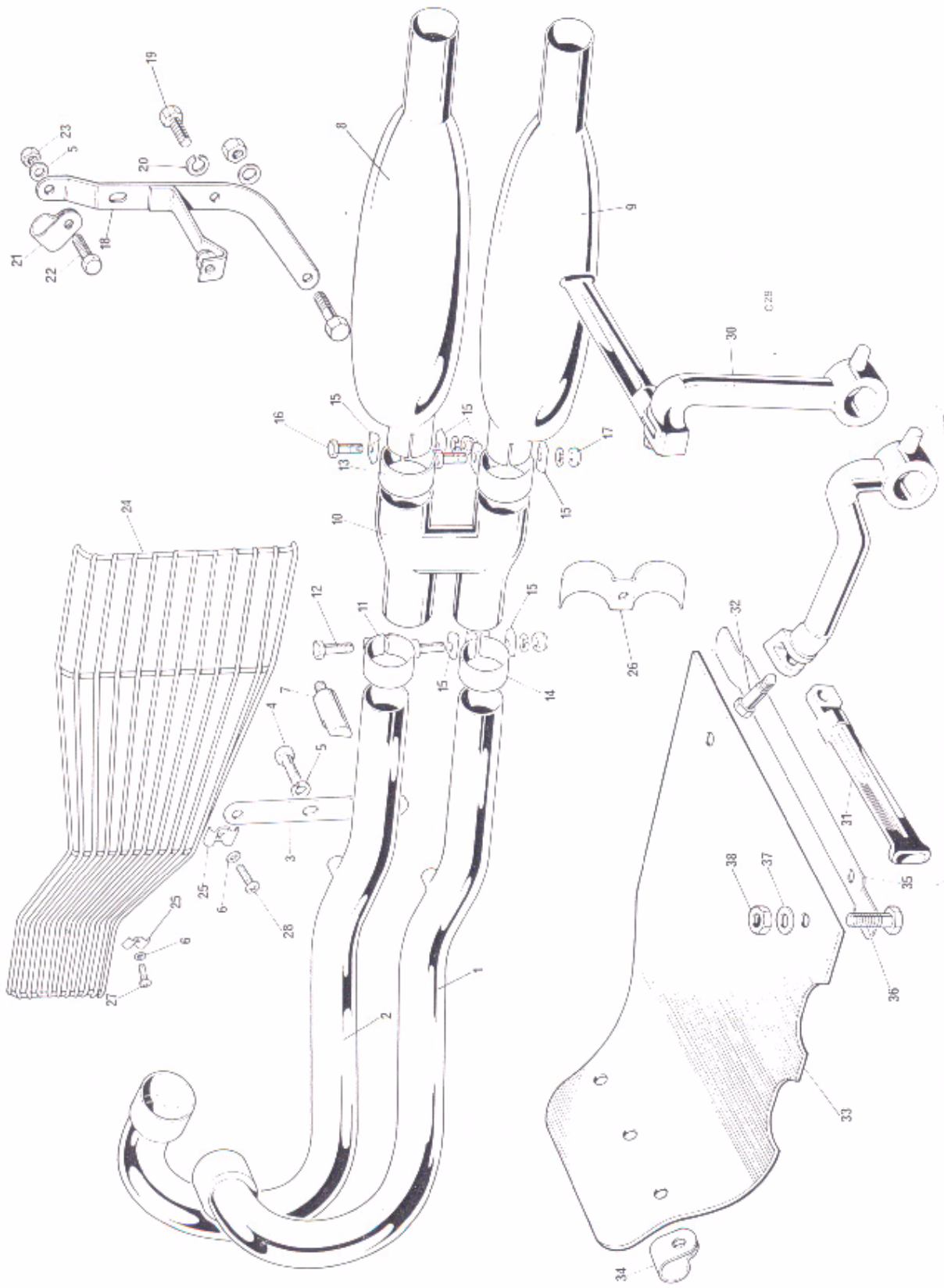

Fig. 17. EXHAUST PIPES, UNDERSHIELD AND FOOTPEGS (T100C)

EXHAUST PIPES, UNDERSHIELD AND FOOTPEG (T100C)

1	E12647	Exhaust pipe lower	1
2	E12646	Exhaust pipe upper	1
3	E12645	Tie bar	1
4	14-0101	Bolt	2
5	D2417	Washer	2
6	E9857	Washer	2
7	F7705	Abutment	1
8	E12019	Muffler upper	1
9	E12020	Muffler lower	1
10	E9673	Connector	1
11	E7299	Clip	1
12	14-0116	Bolt	1
13	E2271	Clip	2
14	E5874	Clip	1
15	E3768	"D" washer	6
16	14-0219	Bolt	3
17	14-1202	Nut	3
18	E9691	Bracket (silencer to frame)	1
19	S1822	Bolt	1
20	S25-3	Washer	2
21	F7550	Clip, bracket to frame	1
22	14-0114	Bolt, clip to bracket	1
23	14-1302	Nut	1
24	E9680	Leg guard	1
25	E9688	Clip	2
26	E9696	Bracket	1
27	S1954	Short screw	1
28	S1953	Long screw (1 $\frac{3}{4}$ in. U.H.)	1
29	F11590	LEFT FOLDING FOOTPEG	1
30	F11591	RIGHT FOLDING FOOTPEG	1
31	F6411	Pedal	2
32	S1971	Pivot bolt	2
33	F11279	Undershield	1
34	F1700	Clip, undershield	2
35	F3078	Bracket	1
36	14-0102	Bolt	4
37	S25-1	Washer	4
38	14-1301	Nut	4

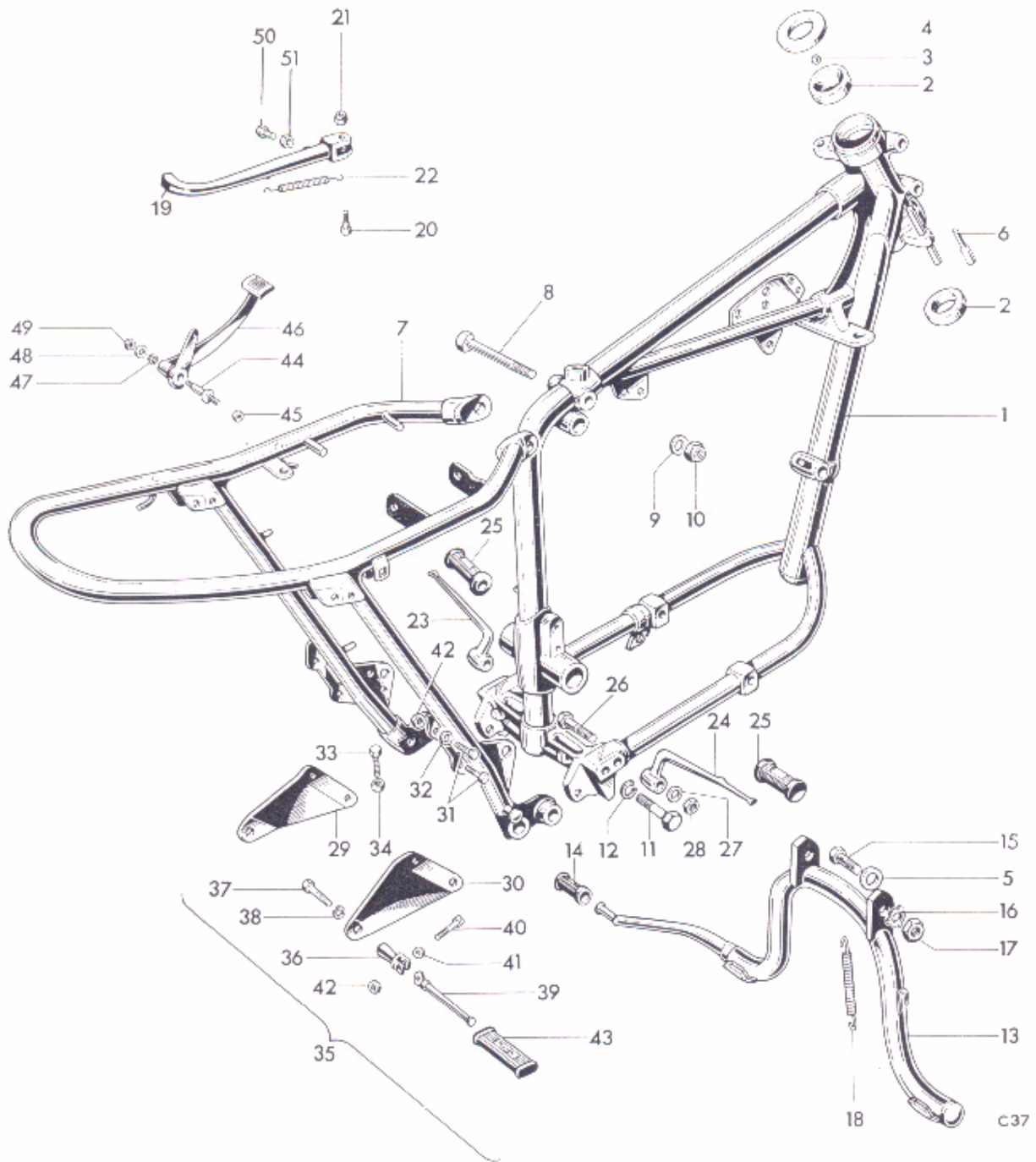

Fig. 18. FRAME

Ref. No.	Part No.	DESCRIPTION	QUANTITY	REMARKS
FRAME				
1	F10034	Front frame	1	
2	H111	Steering race cup	2	
3	D2364	Steel ball (¼ in. dia.)	40	
4	H1018	Top cone and dust cover	1	
5	F5679	Washer	2	T100R only
6	F7155	Steering stops	2	
7	F8038	Rear frame	1	
8	14-0241	Bolt	1	
9	S25-2	Washer	1	
10	14-1303	Nut	1	
11	S588	Bolt	2	
12	99-0046	Spring washer	2	
13	F7693	Centre stand	1	} T100R only
14	T2331	Pedal rubber	1	
15	F5678	Pivot bolt	2	
16	F4484	Tab washer	2	
17	F2725	Nut	2	
18	F3617	Return spring	1	
19	F11560	Prop stand	1	
20	F7021	Pivot bolt	1	
21	14-0703	Self-locking nut	1	
22	F8382	Return spring	1	
23	F4214	Left footrest	1	
24	F4215	Right footrest	1	
25	NF704	Pedal rubber	2	
26	14-0251	Bolt	2	
27	F4370	Plain washer	2	
28	14-1304	Nut	2	
29	F5087	Left pillion footrest support	1	
30	F5088	Right pillion footrest support	1	
31	14-0115	Bolt (¾ in. U.H.)	4	
32	S25-3	Washer	4	
33	F7705	Pedal stop screw	1	
34	14-0302	Nut	2	
35	F9369	PILLION FOOTREST	2	
36	F9370	Footrest hanger	2	
37	S1910	Bolt	2	
38	S26-1	Washer	2	
39	F1694	Pedal	2	
40	F9371	Pivot bolt	2	
41	F2277	Washer	2	
42	14-1302	Nut	6	
43	F1695	Pedal rubber	2	
44	F7706	Brake pedal spindle	1	
45	14-1305	Nut	1	
46	F7703	Brake pedal	1	
47	D3541	Spring washer	1	
48	S25-2	Plain washer	1	
49	14-0403	Nut	1	
50	14-0216	Bolt	1	
51	14-0402	Nut	1	
Not illus.	D2452	Transfer, 'Safety Standards'	1	

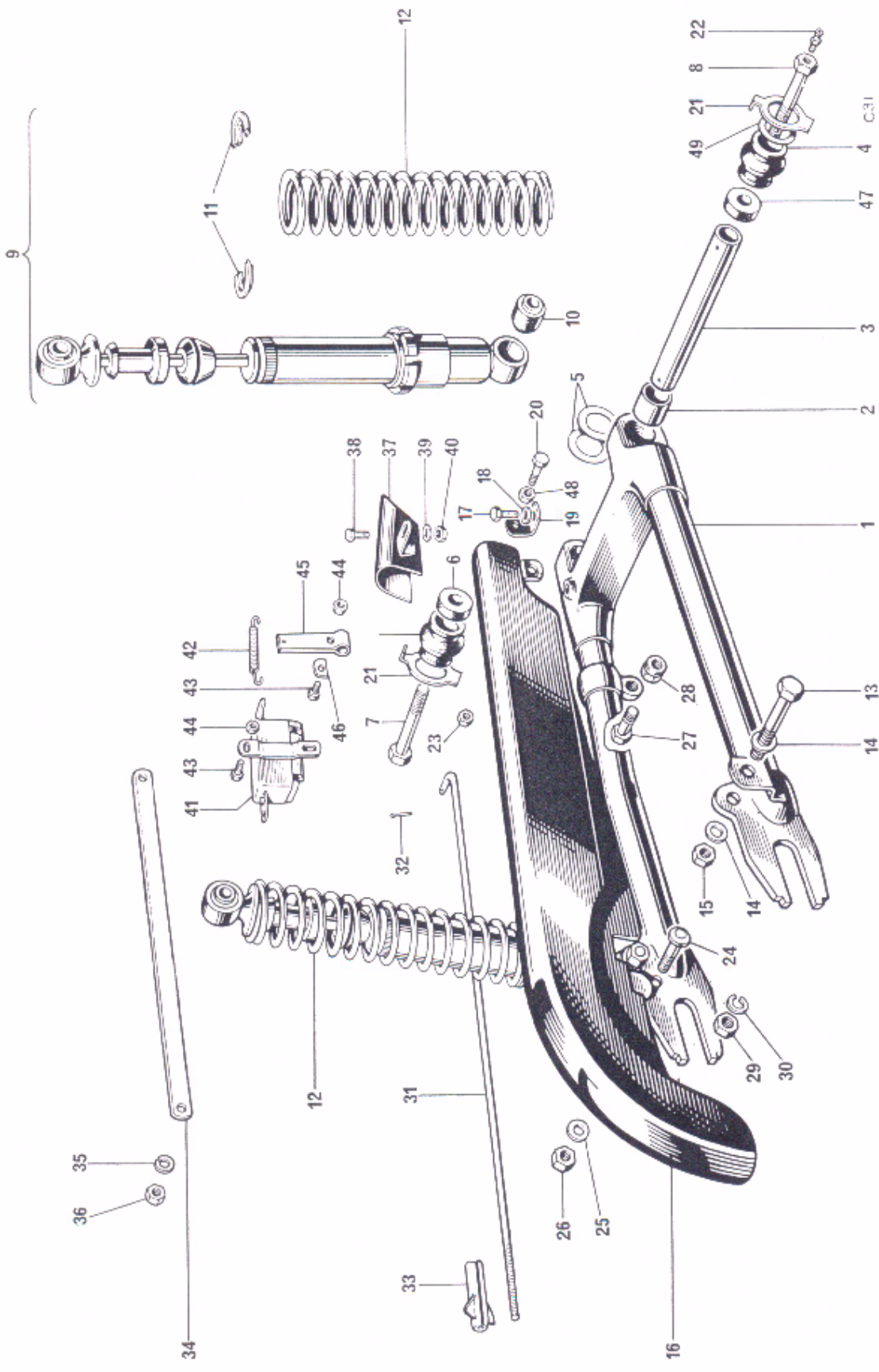

Fig. 19. SWINGING ARM, SUSPENSION UNITS AND CHAINGUARD

SWINGING ARM, SUSPENSION UNITS AND CHAINGUARD

1	F7375	SWINGING ARM	...	1
2	F4076	Pivot bush	...	2
3	F7342	Spindle	...	1
4	F7270	Gaiter	...	2
5	F4385	Shim 0.003 in.	...	As required
5	F4386	Shim 0.005 in.	...	As required
6	F10037	Left distance piece	...	1
7	S580	Pivot bolt—left	...	1
8	S579	Pivot bolt—right	...	1
9	64052107	SUSPENSION UNIT (D2024)	...	2
10	64533645	Bonded bush (99-0122)	...	4
11	9054/171	Spring retainer (99-0107)	...	4
12	64543708	Spring, 100 lbs. chrome (99-1048)	...	2
13	14-0235	Unit fixing bolt	...	4
14	S25-2	Plain washer	...	8
15	14-1303	Nut	...	4
16	F7707	Chainguard	...	1
17	14-0101	Bolt	...	1
18	S26-2	Washer	...	1
19	F4134	Front bracket	...	1
20	14-0113	Bolt	...	1
21	F7343	Tab washer	...	2
22	NW100	Lubricator	...	1
23	14-0702	Self-locking nut	...	1
24	F9387	Stepped bolt	...	1
25	S25-3	Plain washer	...	1
26	14-1302	Nut	...	1
27	14-0128	Bolt	...	1
28	14-1303	Nut	...	1
29	DS47	Nut	...	1
30	99-0046	Spring washer	...	1
31	F7386	Brake operating rod	...	1
32	—	Split pin ($\frac{1}{16}$ in. x $\frac{1}{2}$ in.)	...	Reference only
33	F7387	Adjuster nut	...	1
34	F11780	Brake torque stay	...	1
35	99-0046	Torque stay washer	...	1
36	14-1304	Torque stay nut	...	1
37	F6046	Front chainguard	...	1
38	14-0101	Bolt	...	1
39	S25-1	Washer	...	1
40	14-1301	Nut	...	1
41	54033234	Stop lamp switch (99-0725)	...	1
42	F3158	Spring (315738)	...	1
43	T1076	Bolt ($\frac{3}{8}$ in. U.H.)	...	3
44	F4717	Self-locking nut	...	5
45	F5687	Lever	...	1
46	F5413	"D" washer	...	1
47	F7774	Right distance piece	...	1
48	14-0702	Nut	...	1
49	F4078	Thrust washer	...	1
Not illus.	WE170	Washer, lubricator	...	1
Not illus.	F14277	Distance piece, brake rod	...	1

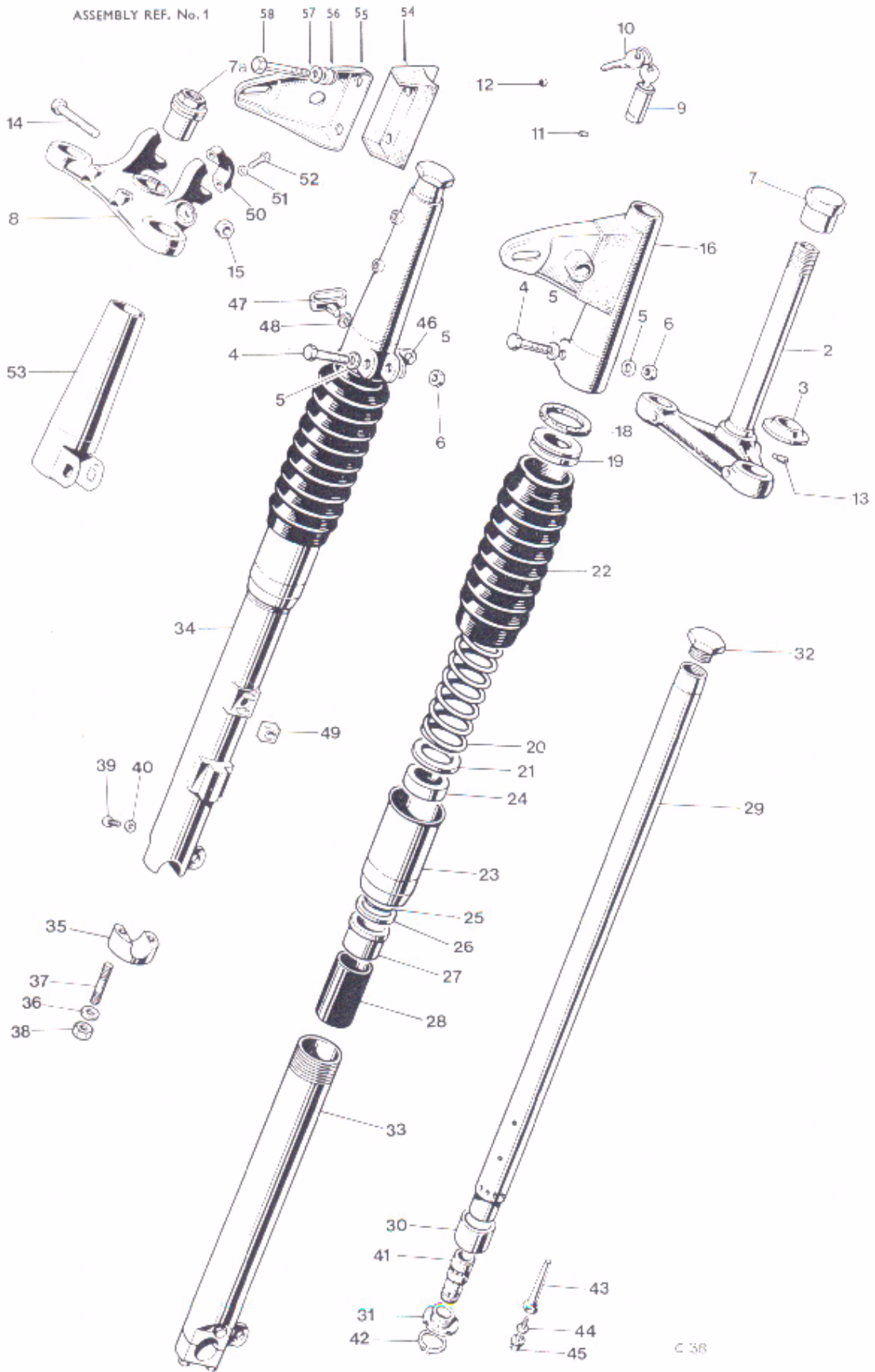

Fig. 20. TELESCOPIC FRONT FORK

Ref. No.	Part No.	DESCRIPTION	QUANTITY	REMARKS
TELESCOPIC FRONT FORK				
1	H4120	FORK ASSEMBLY	1	T100R
1	H4119	FORK ASSEMBLY	1	T100C
2	H2288	Middle lug and stem	1	
3	H439	Bottom cone	1	
4	H2290	Pinch bolt (2 $\frac{1}{4}$ in. U.H.)	2	
5	S25-2	Plain washer	3	
6	14-1303	Cleveloc nut	2	
7A	H2108	Fork stem sleeve nut	1	T100C
7	H2263	Fork stem sleeve nut	1	T100R
8	H3662	Top lug	2	
9	F6738	Lock c/w 2 keys	1	
10	D623	Key (state serial number)	1	Key no's run from EJR 1 to EJR 50
11	S578	Grub screw	1	
12	H2266	Sealing washer	1	
13	H2107	Locating pin	1	
14	S684	Pinch bolt (1 $\frac{5}{8}$ in. U.H.)	1	
15	S685	Seated nut	1	
16	H2198	Left top cover	1	
17	H2199	Right top cover	1	
18	F4074	Cork washer	2	
19	H1657	Spring abutment	2	
20	H1892	Main spring (Yellow/Green)	2	T100C
20	H1891	Main spring (Yellow/Blue)	2	T100R
21	D3273	Plain washer	2	
22	H3635	Telescopic gaiter	2	
23	H4167	DUST EXCLUDER SLEEVE NUT	2	
24	D3274	Oil seal	2	
25	H2119	"O" ring	2	
26	H431	Plain washer	2	
27	H441	Top bearing	2	
28	H1896	Damping sleeve	2	
29	H3904	STANCHION	2	
30	H443	Lower bearing	2	
31	H2091	Bearing nut	2	
32	H2245	Cap nut	2	
33	H3921	LEFT BOTTOM MEMBER c/w CAP	1	
34	H3922	RIGHT BOTTOM MEMBER c/w CAP	1	
35	H1844	Spindle cap	2	
36	E3446	Plain washer	4	
37	S2024	Stud	4	
38	14-1202	Nut, self locking	4	
39	H3894	Drain plug	2	
40	H3893	Sealing washer	2	
41	H2154	Shuttle valve	2	
42	H2127	Circlip	2	
43	H2090	Restrictor	2	
44	H1062	Aluminium washer	2	
45	H2126	Flanged bolt	2	
46	H3682	Bracket	1	
47	H2270	Cable retainer	1	
48	F8245	Starlock washer	1	

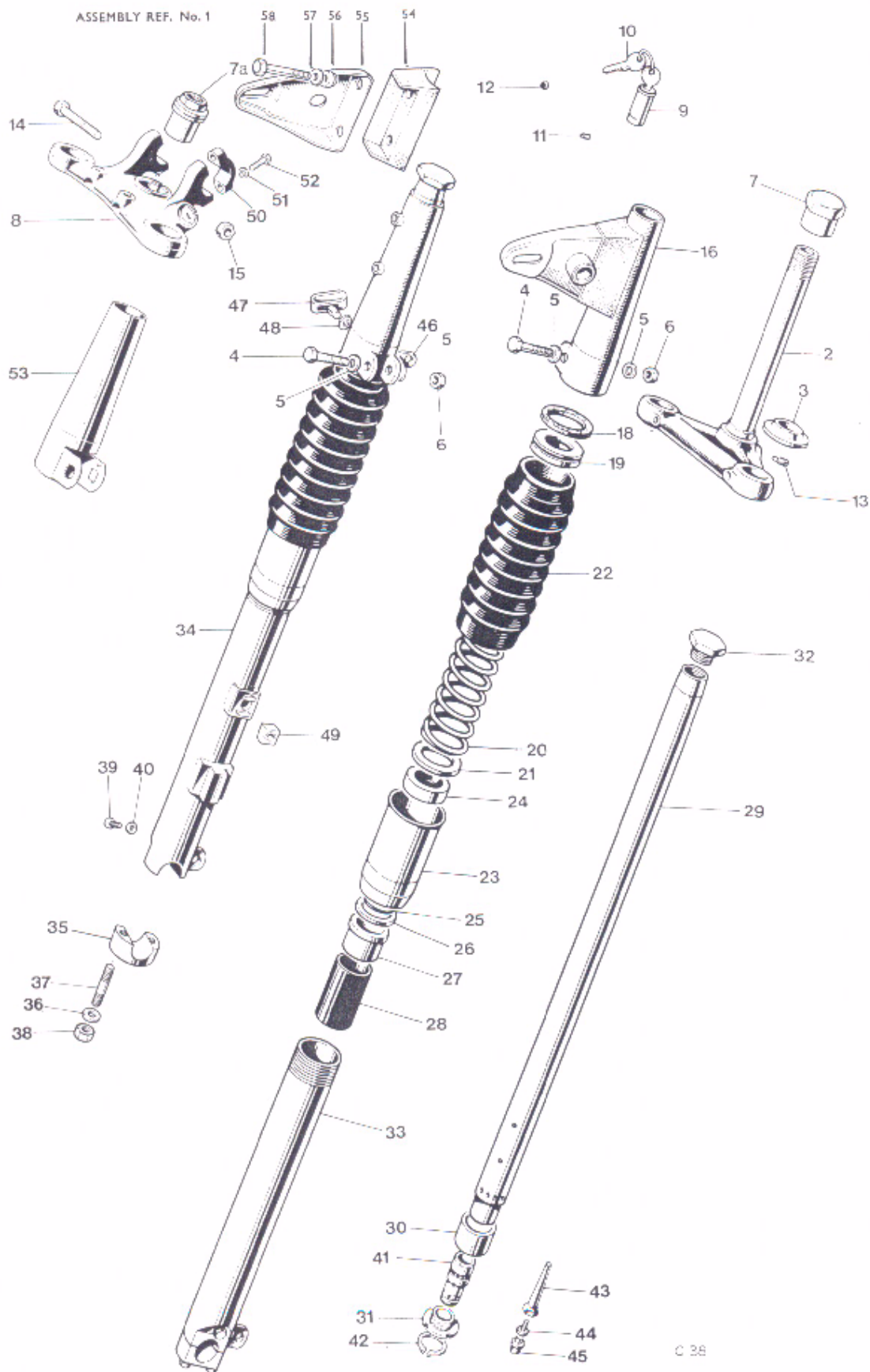

Fig. 20. TELESCOPIC FRONT FORK

TELESCOPIC FRONT FORK (continued)

49	H3926	Square nut	2	
50	H722	Cap	2	
51	S25-3	Plain washer	4	
52	S589	Bolt (1 $\frac{1}{8}$ in. U.H.)	4	
53	H1696	Top cover		Available for use where headlamp removed
54	H2208	Rubber mounting, headlamp bracket	2	
55	H4121	Headlamp bracket—D.S.	1	
55	H4203	Headlamp bracket—T.S.	1	
56	H2209	Rubber buffer	4	
57	H2210	Washer, headlamp bracket	4	
58	S2095	Attachment bolt	4	
Not illus.	F6784	Cable grommet (right top cover)	1	

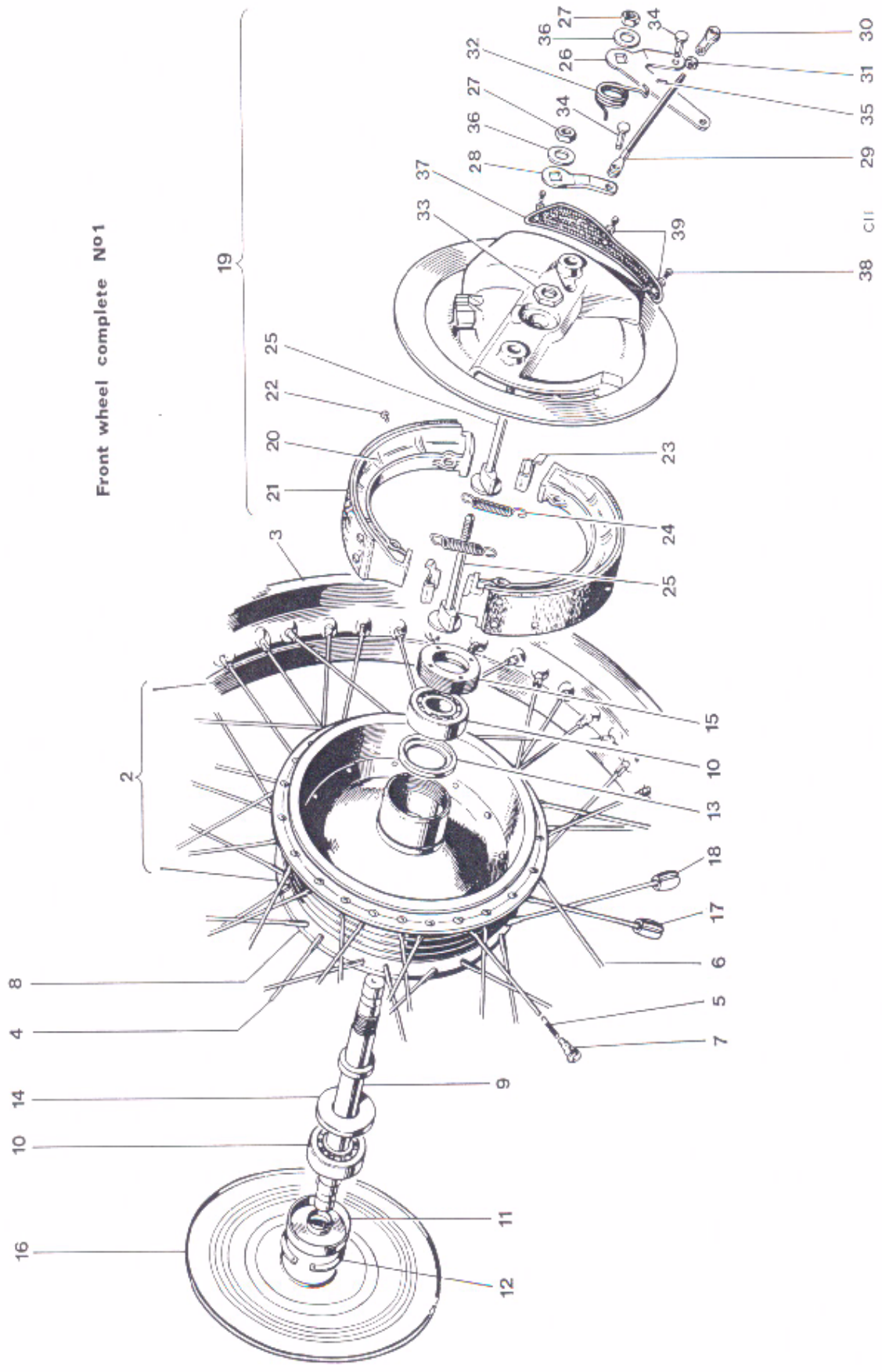

Fig. 21. FRONT WHEEL T100R

Ref. No.	Part No.	DESCRIPTION	QUANTITY	REMARKS
FRONT WHEEL (T100R)				
1	W3458	FRONT WHEEL COMPLETE	1	
2	W1721	RIM, SPOKES AND HUB ASSEMBLY	1	
3	W1230	Front wheel rim (WM2-19)	1	
4	W1328	Spoke (8/10G x 5 ⁵ / ₈ in. straight) c/w nipple	20	
5	W1708	Spoke (8/10G x 4 ³ / ₈ in. 78°) c/w nipple	10	
6	W1709	Spoke (8/10G x 4 ⁷ / ₈ in. 100°) c/w nipple	10	
7	S79-2	Spoke nipple	40	
8	W1722	Hub and brake drum	1	
9	W3582	Wheel spindle	1	
10	W653	Bearing	2	
11	W1237	Dust cover	1	
12	T280	Circlip	1	
13	W3337	Bearing support ring	1	
14	W1481	Grease retainer	1	
15	W582	Retaining ring	1	
16	W3460	Cover plate	1	
17	W1197	Balance weight, 1/2 oz.	As required	
18	W1198	Balance weight, 1 oz.	As required	
19	W3461	BRAKE ANCHOR PLATE ASSEMBLY	1	
20	W1996	BRAKE SHOE c/w LINING	2	
21	Reference only	Brake lining	1	} Each shoe
22	Reference only	Brass rivet	8	
23	W2026	Thrust pad	2	
24	W135	Shoe return spring	2	
25	W2001	Brake cam	1	
26	W3453	Brake cam lever (front)	1	
27	14-1303	Nut	2	
28	W3454	Brake cam lever (rear)	1	
29	W2003	Rod assembly	1	
30	W2005	Fork end, threaded	1	
31	14-0401	Locknut	1	
32	W3522	Lever return spring	1	
33	S1995	Anchor plate nut	1	
34	WF32	Pivot pin	2	
35	—	Split pin (1/16 in. x 3/8 in. long)	Reference only	
36	S25-6	Plain washer	2	
37	W1991	Anchor plate gauze (for air scoop)	1	
38	S1998	Taptite screw	3	
39	E2351	Washer for taptite screws	3	

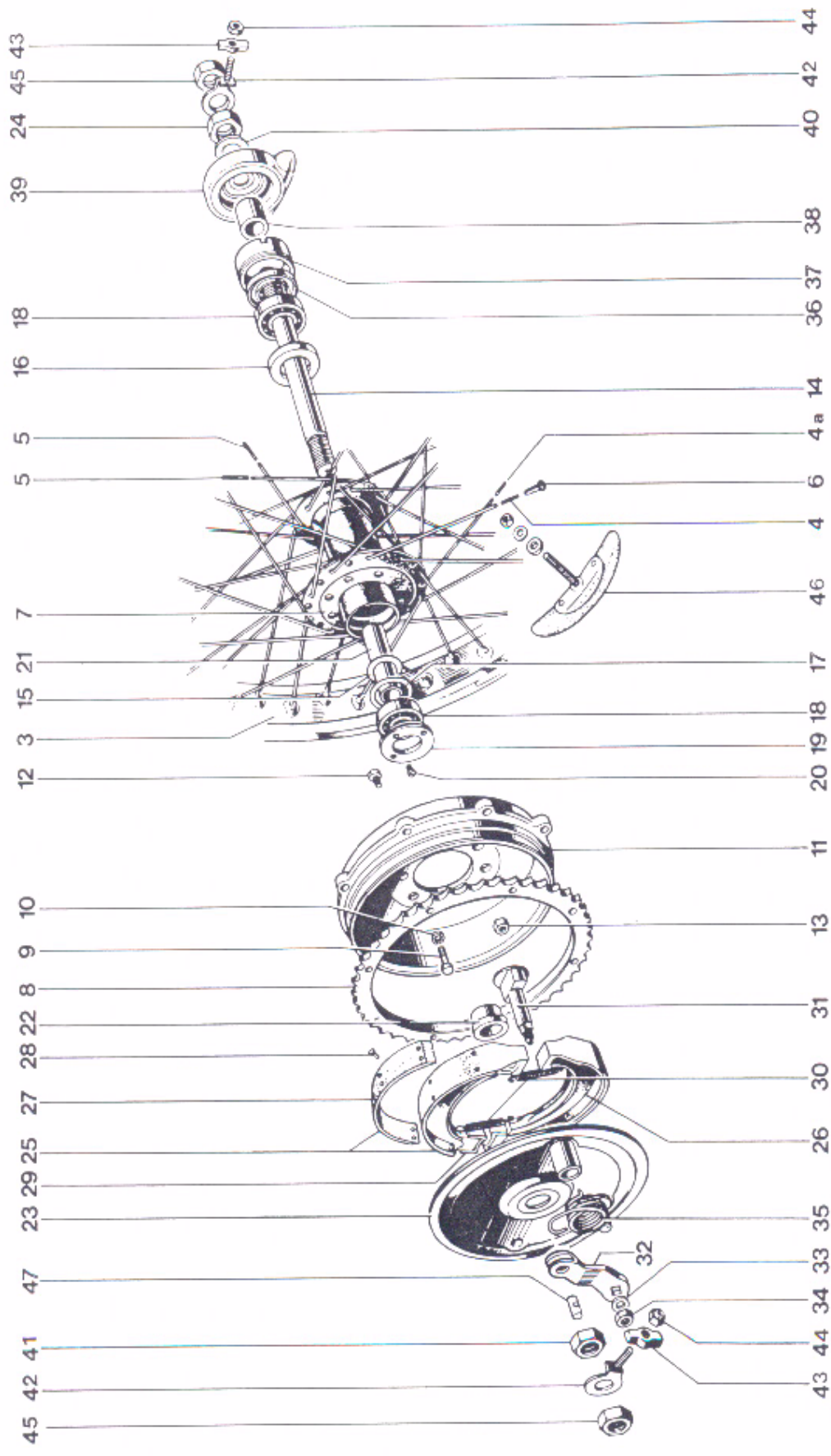

Fig. 23. REAR WHEEL

Ref. No.	Part No.	DESCRIPTION	QUANTITY	REMARKS
FRONT WHEEL (T100C)				
1	W3430	FRONT WHEEL COMPLETE	1	
2	W2132	RIM SPOKES AND HUB ASSEMBLY	1	
3	W1230	Front wheel rim (WM2-19)	1	
4	W2137	Spoke D.S.	20	
5	W2138	Spoke T.S.	10	
6	W2139	Spoke T.S.	10	
7	W2136	Spoke nipple	40	
8	W3325	Hub and brake drum	1	
9	W3582	Wheel spindle	1	
10	W653	Wheel bearing	2	
11	W1237	Dust cover	1	
12	T280	Circlip	1	
13	W3337	Bearing support ring	1	
14	W1481	Grease retainer	1	
15	W582	Retaining ring	1	
16	W3443	Cover plate	1	
17	W1197	Balance weight $\frac{1}{2}$ oz.	As required	
18	W1198	Balance weight 1 oz.	As required	
19	W3455	BRAKE ANCHOR PLATE ASSEMBLY	1	
20	W3446	BRAKE SHOE c/w LINING	2	
21	Reference only	Brake lining	1	} Each shoe
22	Reference only	Brass rivet	8	
23	W2026	Thrust pad	2	
24	W135	Shoe return spring	2	
25	W2001	Brake cam	1	
26	W3453	Brake cam lever (front)	1	
27	14-1303	Nut	2	
28	W3454	Brake cam lever (rear)	1	
29	W3450	Rod assembly	1	
30	W2005	Fork end, threaded	1	
31	14-0401	Locknut	1	
32	W3522	Lever return spring	1	
33	S1995	Anchor plate nut	1	
34	WF32	Pivot pin	2	
35	—	Split pin ($\frac{1}{16}$ in. x $\frac{3}{8}$ in. long)	Reference only	
36	S25-6	Plain washer	2	
37	W1991	Anchor plate gauze (for air scoop)	1	
38	S1998	Taptite screw	3	
39	E2351	Washer for taptite screws	3	

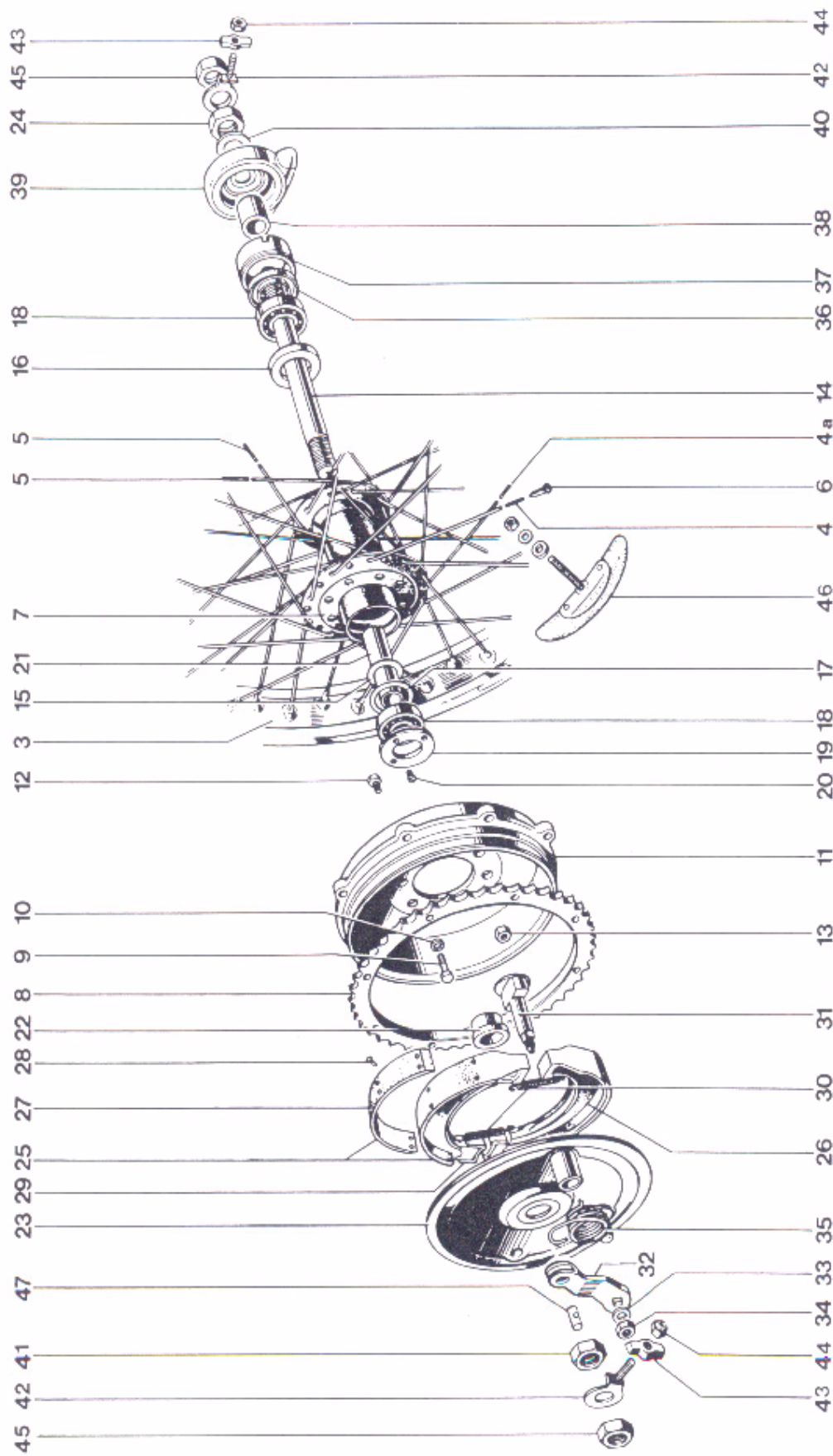

Fig. 23. REAR WHEEL

REAR WHEEL

1	W3607	REAR WHEEL COMPLETE	1	
2	W3610	RIM, SPOKES AND HUB ASSEMBLY	1	
3	W1007	Rear wheel rim WM3-18	1	
4	W1107	Spoke (8/10G x 7 ⁹ / ₁₆ in. 90°)	10	
4A	W3402	Spoke (8/10G x 7 ⁷ / ₁₆ in. 110°)	10	
5	W1108	Spoke (8/10G x 7 ⁷ / ₈ in. 90°)	20	
6	S79-2	Spoke nipple	40	
7	W3586	Hub	1	
8	W1499	Sprocket, 46T	1	
9	S2010	Bolt	8	
10	E1612	Serrated washer	8	
11	W3585	Brake drum	1	
12	S2011	Bolt (1 ¹ / ₈ in. U.H.)	8	
13	14-1202	Self-locking nut	8	
14	W3589	Wheel spindle	1	
15	W1474	Grease retainer (brake side)	1	
16	W1654	Grease retainer	1	
17	W1022	Backing ring	1	
18	W653	Bearing	2	
19	W3587	RETAINING RING	1	
20	W1710	Locking screw (5 ⁵ / ₁₆ in. U.H.)	1	
21	W1278	Distance tube	1	
22	W1024	Distance piece	1	
23	W3590	Brake anchor plate	1	
24	S2013	Nut	1	
25	W1406	LEADING BRAKE SHOE C/W LINING	1	
26	W1407	TRAILING BRAKE SHOE C/W LINING	1	
27	Reference only	Brake lining	2	
28	Reference only	Brass rivet	16	
29	W1415	Thrust pad	2	
30	W135	Shoe return spring	2	
31	W3592	Brake cam	1	
32	W2014	Brake cam lever	1	
33	S25-6	Plain washer	1	
34	S1-52	Nut	1	
35	W1488	Lever return spring	1	
36	W1635	Grease retainer	1	
37	W3588	Speedometer adaptor	1	
38	W1477	Distance piece	1	
39	D373	Speedometer gearbox	1	
40	W1280	Plain washer	1	
41	S2014	Nut D.S. inner	1	
42	W2089	Chain adjuster	2	
43	W1015	Adjuster end plate	2	
44	14-1902	Self-locking nut	2	
45	S585	Spindle nut	2	
46	W3468	Tyre security bolt WM3	2	
47	W11	Pivot pin	1	

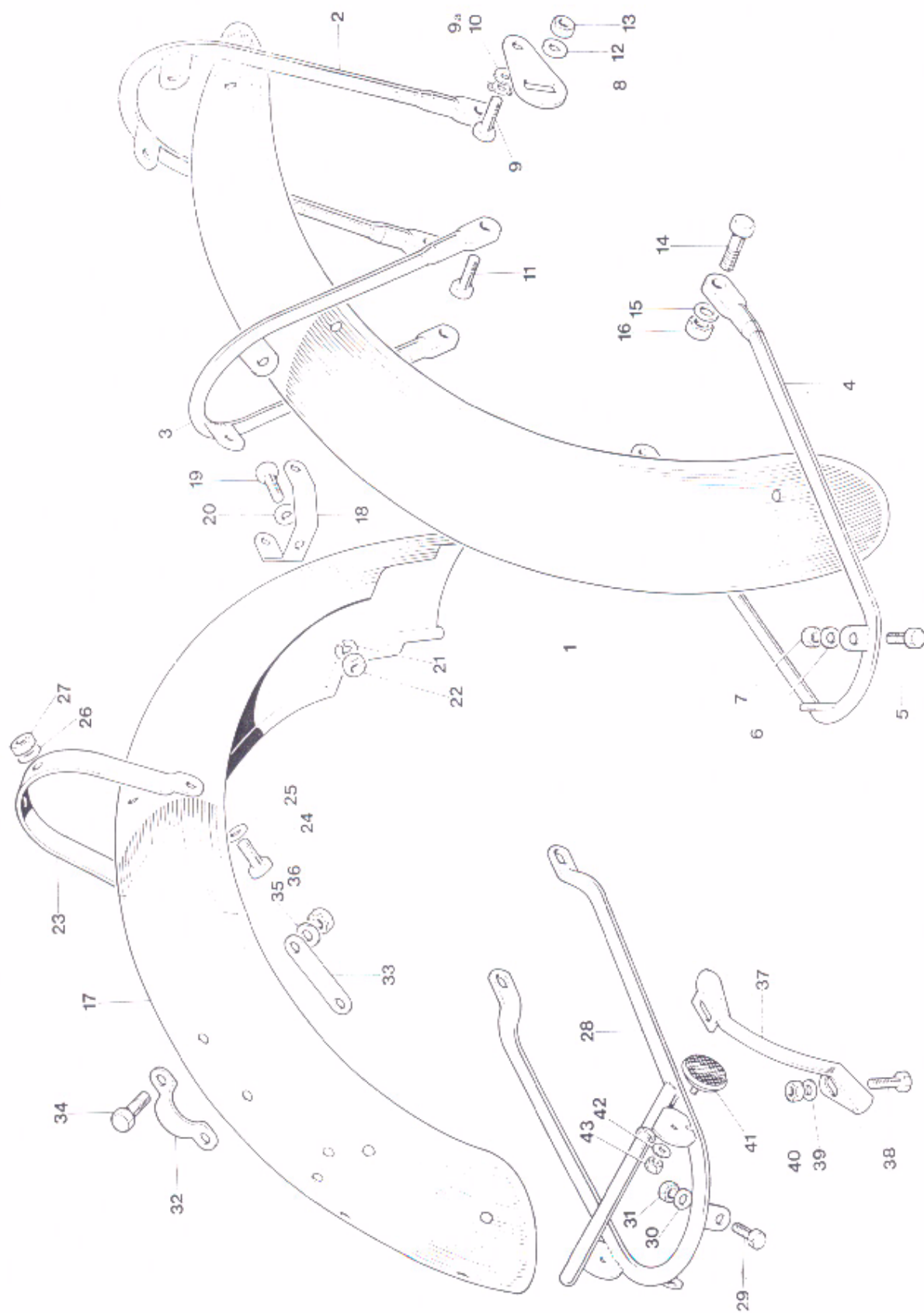
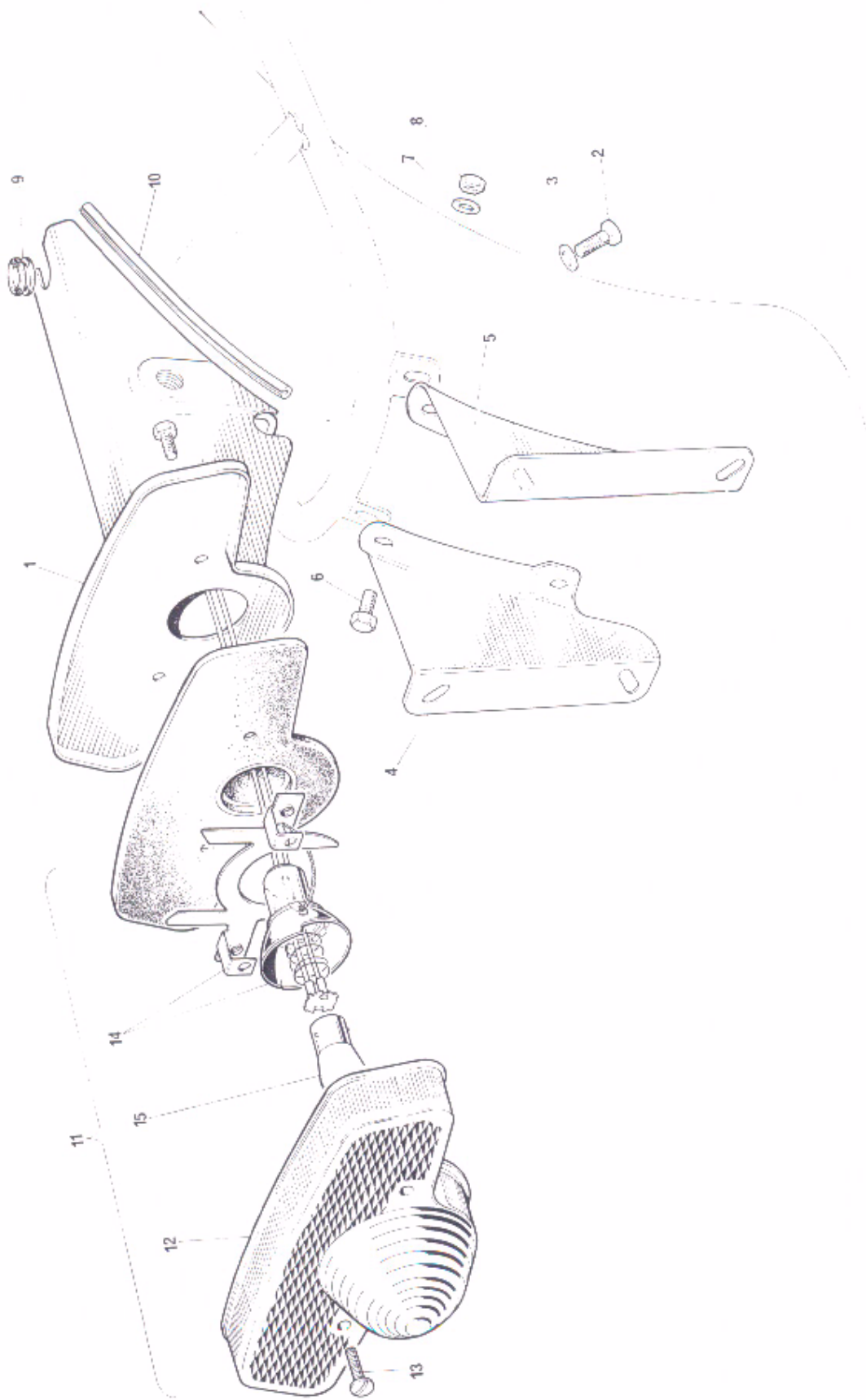

Fig. 24. FENDERS

F E N D E R S

1	H3884	Front fender (stainless)	1	T100C
1	H3882	Front fender	1	T100R
2	H3663	Front stay	1	T100R
2	H1681	Front stay	1	T100C
3	H3664	Centre stay	1	T100R
3	H1683	Centre stay	1	T100C
4	H4046	Bottom stay	1	T100R
4	H3885	Bottom stay	1	T100C
5	14-0101	Bolt	6	
6	S25-1	Washer	6	
7	14-1201	Nut (Cleveland)	6	
8	H1685	Bracket D.S. and T.S. fork leg to stays	2	T100R
8	H1688	Bracket D.S. and T.S. fork leg to stays	2	T100C
9	14-0113	Bolt	2	
9A	H4071	Tab washer	2	
10	D3025	Washer	2	
11	14-0115	Bolt	2	
12	F4299	Washer	2	
13	14-1302	Nut	2	
14	14-0115	Bolt	2	
15	S25-3	Washer	2	
16	14-0702	Nut	2	
17	F12995	Rear fender (stainless)	1	T100C
17	F12876	Rear fender	1	T100R
18	F6916	Bracket	1	
19	14-0101	Bolt	1	
20	F6310	Washer	1	
21	S26-2	Washer	1	
22	14-1201	Nut (Cleveland)	1	
23	F6915	Bridge	1	
24	14-0102	Bolt	2	
25	F6310	Washer	2	
26	S25-1	Washer	2	
27	14-1201	Nut (Cleveland)	2	
28	F12879	Lifting handle	1	
29	14-0102	Bolt	2	
30	S25-1	Washer	2	
31	14-1201	Nut (Cleveland)	2	
32	F5994	Clip	1	
33	F6031	Backing plate	1	
34	14-0113	Bolt	2	
35	S25-3	Washer	2	
36	14-1302	Nut (Cleveland)	2	
37	F7826	Wiring protector	1	
38	14-0102	Bolt	2	
39	S25-1	Washer	2	
40	14-1201	Nut (Cleveland)	2	
41	57079	Reflector—red (99-1162)	2	
42	D2391	Washer	2	
43	F4717	Nut	2	
Not illus.	D343/3	Cable clip	1	



C 50

Fig. 25. TAIL LAMP AND SUPPORT

TAIL LAMP AND SUPPORT

1	F12877	Tail lamp support	1	
2	14-0101	Bolt	2	} Tail lamp support—rear fixing
3	D2426	Washer	2	
4	F12727	Rear number plate bracket—L.H.	1	
5	F12728	Rear number plate bracket—R.H.	1	
6	14-0101	Bolt	4	} Number plate bracket to fender
7	D2338	Washer	4	
8	14-1301	Nut	4	
9	H961	Grommet—tail lamp lead	1	
10	F13275	Rubber bleeding strip	2	
11	53973	STOP AND TAIL LAMP—679 (99-0597)	1	
12	54577109	Lens (99-1046)	1	
13	144921	Screw (99-1189)	2	
14	54525286	Lamp base assembly		Reference only
15	380	Bulb (99-0542)	1	

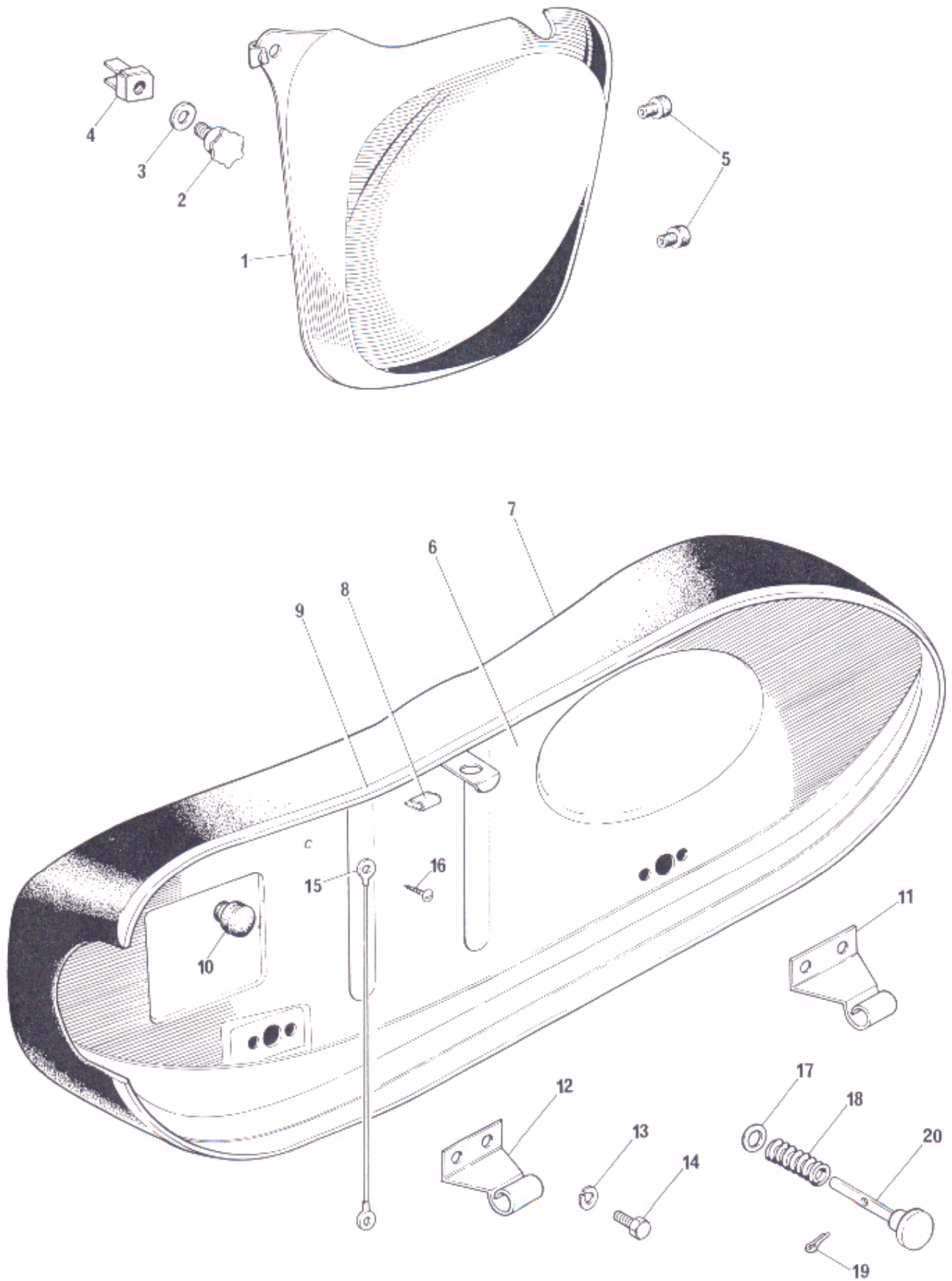

Fig. 26. PANELS AND TWINSEAT

PANELS AND TWINSEAT

1	F11358	Left panel and toolbox	1	
2	F11357	Toolbox screw	1	
3	F11377	Washer	1	
4	F10222	Captive nut	1	
5	F6673	Grommet	2	
6	F11573	TWINSEAT	1	
7	F9715	Twinseat cover	1	
Not illus.	A52	Transfer, positive earth	1	
8	D697	Sprag	4	
9	D696	Trim strip (bright)	1	
10	F4898	Buffer front	2	
Not illus.	F7835	Buffer rear	2	
11	F8026	Hinge front	1	
12	F7862	Hinge rear	1	
13	S26-2	Spring washer	4	
14	14-0101	Bolt	4	
15	D374	Check wire	1	
16	D2381	Self tapping screw	2	
17	E1719A	Washer	1	
18	F4228	Spring	1	
19	—	Split pin ($\frac{3}{32}$ in. x $\frac{1}{2}$ in.)		Reference only
20	F7560	Seat knob and plunger	1	
Not illus.	{ D2105 D2106	Transfer Trophy 500	1	T100C
		Transfer Daytona	1	T100R

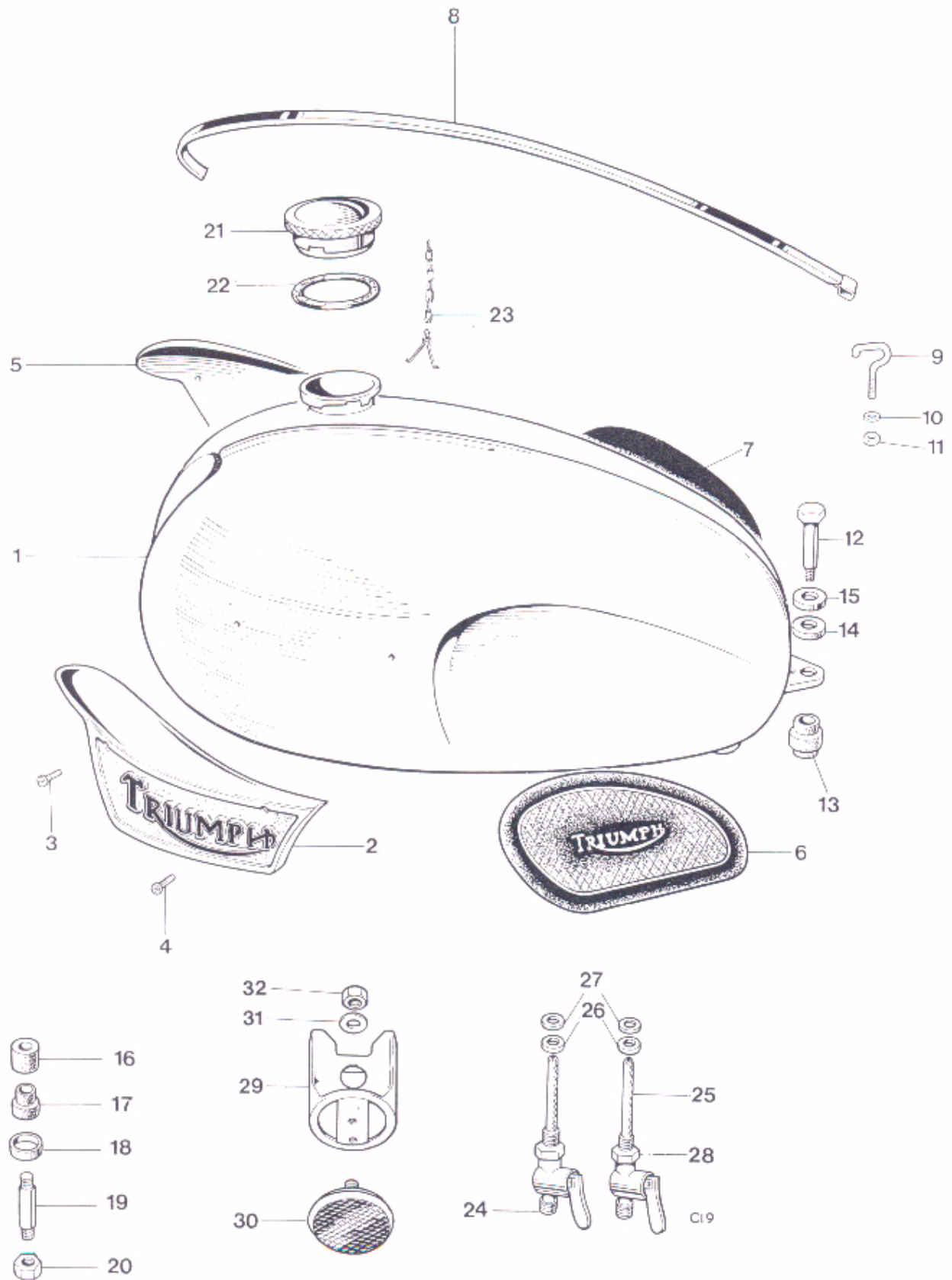

Fig. 27. GAS TANK

Ref. No.	Part No.	DESCRIPTION	QUANTITY	REMARKS
GAS TANKS				
1	F11804	Petrol tank	1	T100R
1	F11803	Petrol tank	1	T100C
2	F9701	Styling unit (left)	1	
3	F11339	Styling unit screw (27/64 in. O.A.) front	2	
4	F7888	Styling unit screw (35/64 in. O.A.) rear	2	
5	F9700	Styling unit (right)	1	
6	F8192	Left knee grip	1	} Available
7	F8193	Right knee grip	1	
8	F10007	Centre styling strip	1	
9	F10008	Hook, screw	1	
10	F4019	Serrated washer	1	
11	H919	Nut	1	
12	F7388	Rear bolt	1	
13	F5336	Double spigot rubber	1	
14	F967	Rubber washer	1	
15	F3814	Cup	1	
16	F5228	Rubber washer	2	
17	F5229	Spigot rubber	2	
18	F3814	Cup	2	
19	S1883	Stud	2	
20	14-1302	Nut	2	
21	F13875	FILLER CAP	1	
22	F4048	Joint washer	1	
23	F3217	Jack chain	1	
24	F12801	Petrol tap—D.S.	1	
25	F12800	Petrol tap—T.S.	1	
26	E7351	Petrol tap seal	2	
27	F10002	Steel washer	2	
28	F10006	Tap nut	2	
29	F12903	Reflector bracket	2	
30	57183	Reflector, amber (99-1161)	2	
31	D2391	Washer (front reflectors)	2	
32	F4717	Nut (front reflectors)	2	
Not illus.	{ A56 A61 D2105 D2106	Transfer, World Speed Record	1	
		Transfer, Made in England	1	
		Transfer, Trophy 500	1	
		Transfer, Daytona	1	

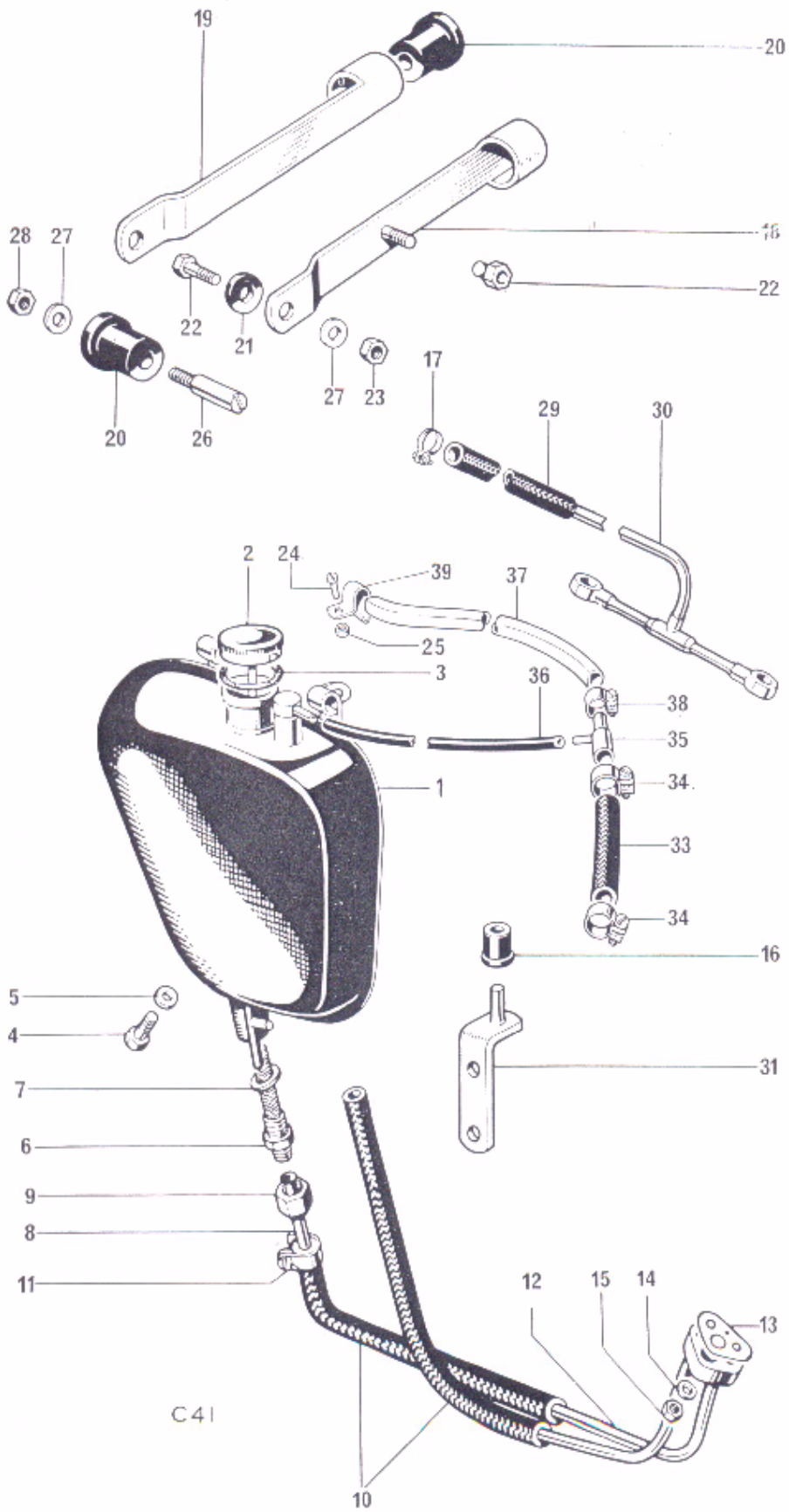

Fig. 28. OIL TANK

Ref. No.	Part No.	DESCRIPTION	QUANTITY	REMARKS
----------	----------	-------------	----------	---------

OIL TANK

1	F13290	Oil tank	1	
2	F9659	FILLER CAP AND DIPSTICK	1	
3	F4047	Joint washer	1	
4	F5343	Drain plug	1	
5	99-0048	Fibre washer	1	
6	F3179	Oil tank filter	1	
7	F1713	Fibre washer	1	
8	F3655	Upper feed pipe	1	
9	F3182	Union nut	1	
10	E4594	Flexible connector, long	2	
11	E6848	Clip	4	
12	E7203	Oil pipes and junction block	1	
13	E11458	Joint washer	1	
14	E3446	Plain washer	1	
15	S1908	Nut	1	
16	F6039	Grommet	1	
17	E6849	Clip (rocker pipe)	1	
18	F9255	Front strap	1	
19	F8028	Rear strap	1	
20	F6673	Spigot rubber	4	
21	F6968	Rubber washer	2	
22	14-0103	Bolt	2	
23	14-0701	Self-locking nut	2	
24	H3894	2 BA Screw	4	
25	F4717	2 BA Nut	4	
26	F7510	Screwed peg	2	
27	S25-13	Plain washer	4	
28	14-1301	Nut	3	
29	E6353	Rubber connector	1	
30	E7576	Rocker oil feed pipe	1	
31	F6898	Bracket	1	
32	F8034	Spigot nut	1	
Not illus.	D1816	Grouped transfer "Drain and Refill" etc.	1	
33	E11149	Breather vent pipe	1	
34	D2253	Clip breather vent pipe	2	
35	F11610	'T' piece connector	1	
36	F11613	Froth tower vent pipe	1	
37	F11614	Breather pipe, rear guard	1	
38	D2252	Clip, pipe to 'T' piece	1	
39	F11615	Clip, pipe to rear guard	1	

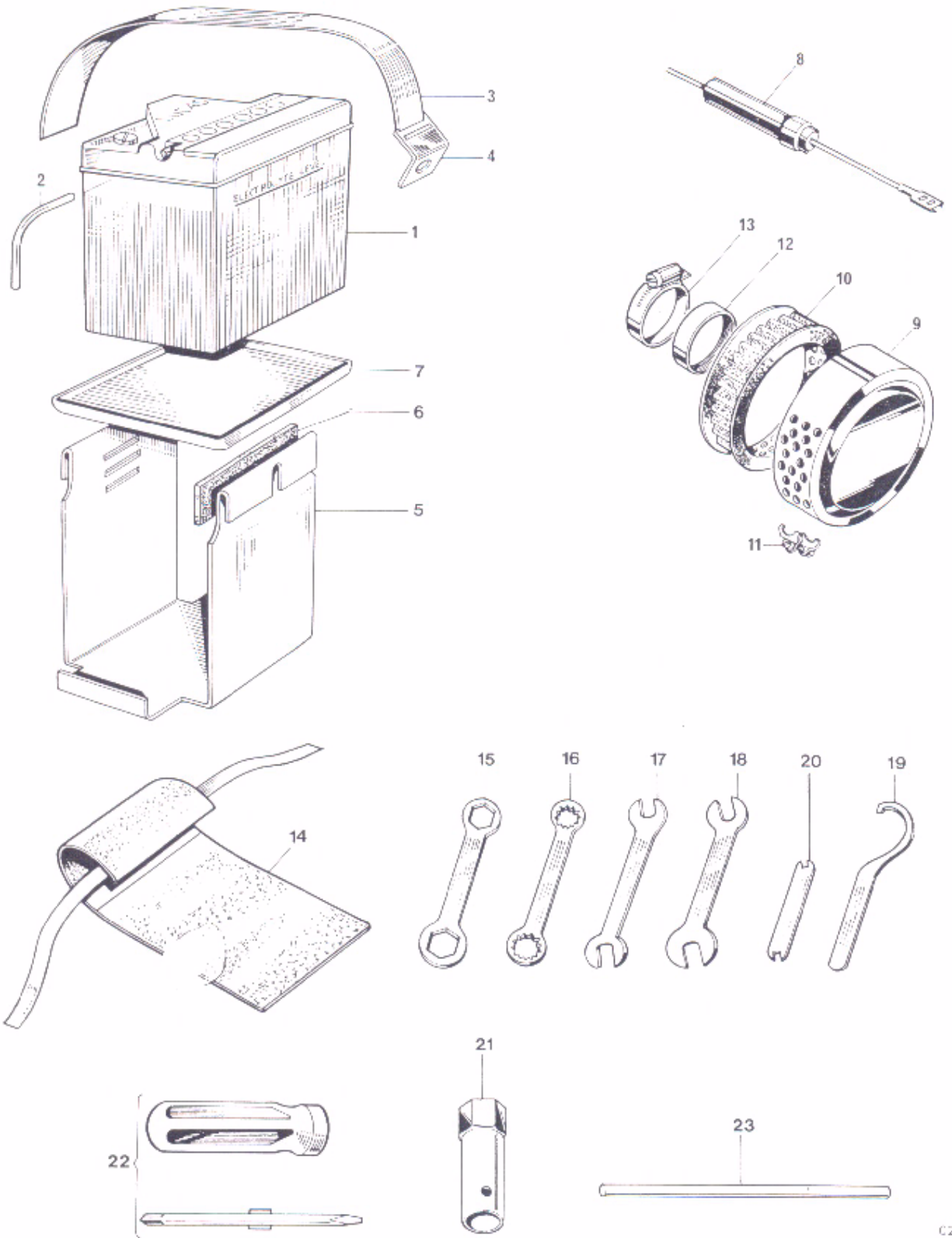

Fig. 29. BATTERY, TOOLKIT AND AIR FILTER

C2B

BATTERY, TOOLKIT AND AIR FILTER

1	54027029	Battery PUZ5A (99-0719)	1	
2	F7431	Vent pipe	1	
3	F8033	Battery retaining strap	1	
4	F8032	Battery strap anchorage	1	
5	F8024	Battery carrier	1	
6	F8031	Battery carrier rubber	1	
7	F8091	Battery carrier tray	1	
8	54938986	Fuse assembly		Reference only
9	F11609	AIR FILTER	1 or 2	
10	F6866	Filter element (Filter cloth and gauze)	1 or 2	
11	F4810	Clip for cover	1 or 2	
12	E12086	Adaptor	1 or 2	
13	D708	Clip	1	
—	D2110	TOOL KIT	1	
14	D291	Tool roll	1	
15	D2251	Ring spanner $1\frac{1}{8}$ in. x $1\frac{5}{16}$ in. AF.	1	
16	D370	Ring spanner $\frac{3}{8}$ in. x $\frac{1}{4}$ in. WHIT	1	
17	D2084	Open end spanner $\frac{1}{2}$ in. x $\frac{7}{16}$ in. AF.	1	
18	DA16	Open end spanner $\frac{3}{8}$ in. x $\frac{7}{16}$ in. WHIT	1	
19	D2184	C spanner	1	
20	D2185	Tappet spanner	1	
21	DA87	Box spanner for sparking plug	1	
22	D767	Screwdriver c/w blade	1	
23	D1911	Tommy bar	1	

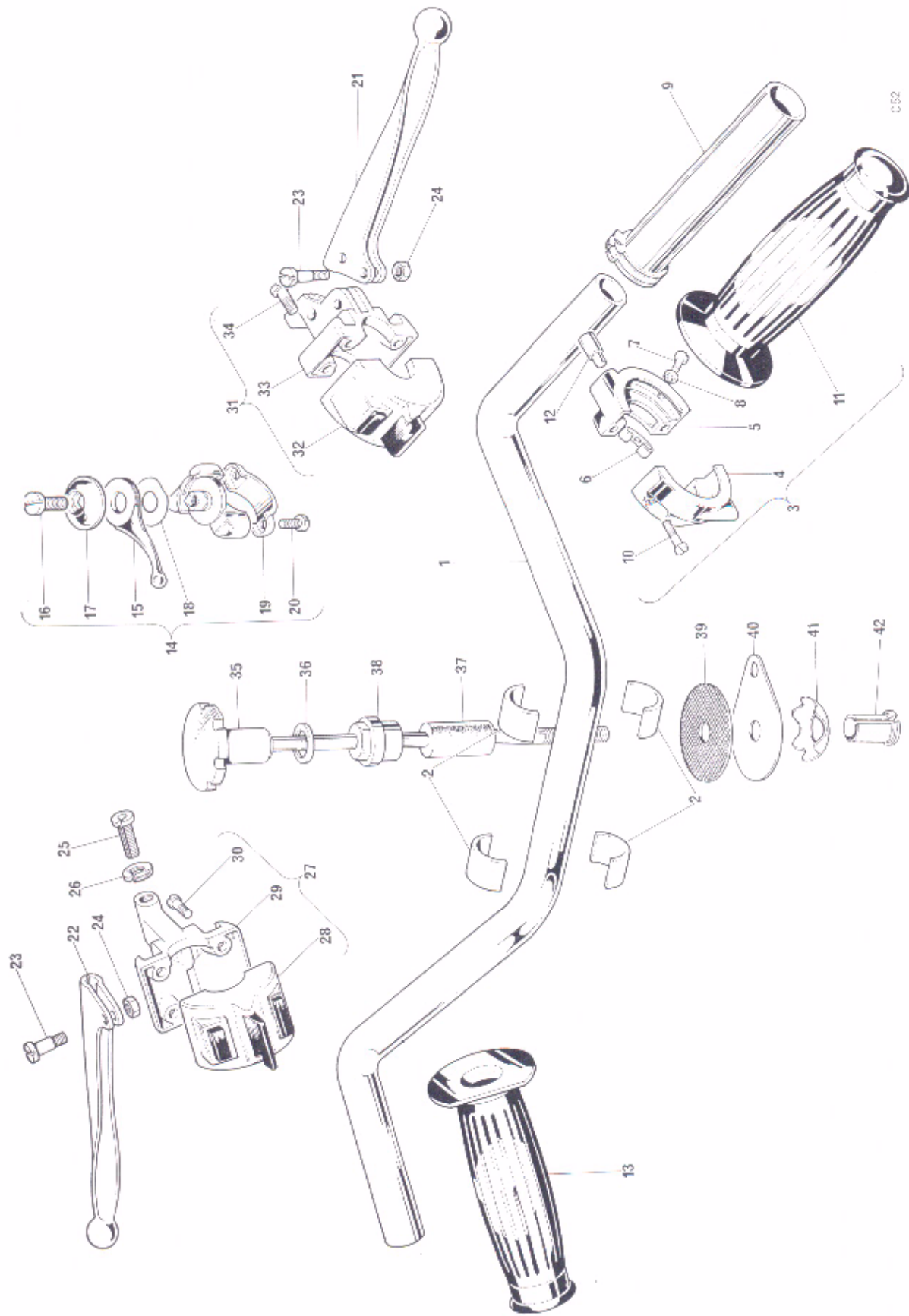

Fig. 30. HANDLEBAR AND CONTROL LEVERS

HANDLEBAR AND CONTROL LEVERS

1	H4251	Handlebar	Available	
1	H4252	Handlebar (Western)	1	
2	H1425	Sleeve, handlebar mounting	4	
3	16/364	TWISTGRIP (99-0248)	1	T100C
4	16/328	Body, top half (99-0245)	1	
5	16/329	BODY, BOTTOM HALF (99-0246)	1	
6	16/008	Friction spring	Reference only	
7	16/009	Screw	Reference only	
8	16/010	Locknut	Reference only	
9	99-0244	Rotor		
10	11/013	Screw (99-0225)	2	
11	H2125	Grip	1	
12	16/011	Cable stop (99-0241)	1	
13	H2124	Grip	1	
14	12/608	AIR CONTROL LEVER (D3246)	1	
15	12/556	Lever	Reference only	
16	12/607	Bolt	Reference only	
17	12/606	Cap	Reference only	
18	12/033	Spring washer	Reference only	
19	12/040	Clamp	Reference only	
20	11/014	Screw	Reference only	
21	D3583	Front brake lever (alloy)	1	
21	D3143	Front brake lever (steel)	1	T100C
22	D3657	Clutch lever (alloy)	1	
22	D3144	Clutch lever (steel)	1	T100C
23	S2048	Pivot pin	2	
24	14-1301	Nut	2	
25	D3585	Adjuster	2	
26	D3586	Lockring	2	
27	39596	HANDLEBAR SWITCH—L.H.	Reference only	
28	54033666	Switch half	Reference only	
29	54340882	Lever half (99-1187)	1	
30	54115246	Screw (99-1188)	4	
31	39595	HANDLEBAR SWITCH—R.H.	Reference only	
32	54033667	Switch half	Reference only	
33	54340883	Lever half (99-1215)	1	
34	54115246	Screw (99-1188)	4	
35	H3602	Steering damper rod c/w knob	1	} T100C
36	H565	Washer	1	
37	H1618	Rubber sleeve	1	
38	H2108	Sleeve nut	1	
39	H435	Friction disc	1	
40	H1797	Anchor plate	1	
41	H95	Spring plate	1	
42	H3601	Adjuster sleeve	1	

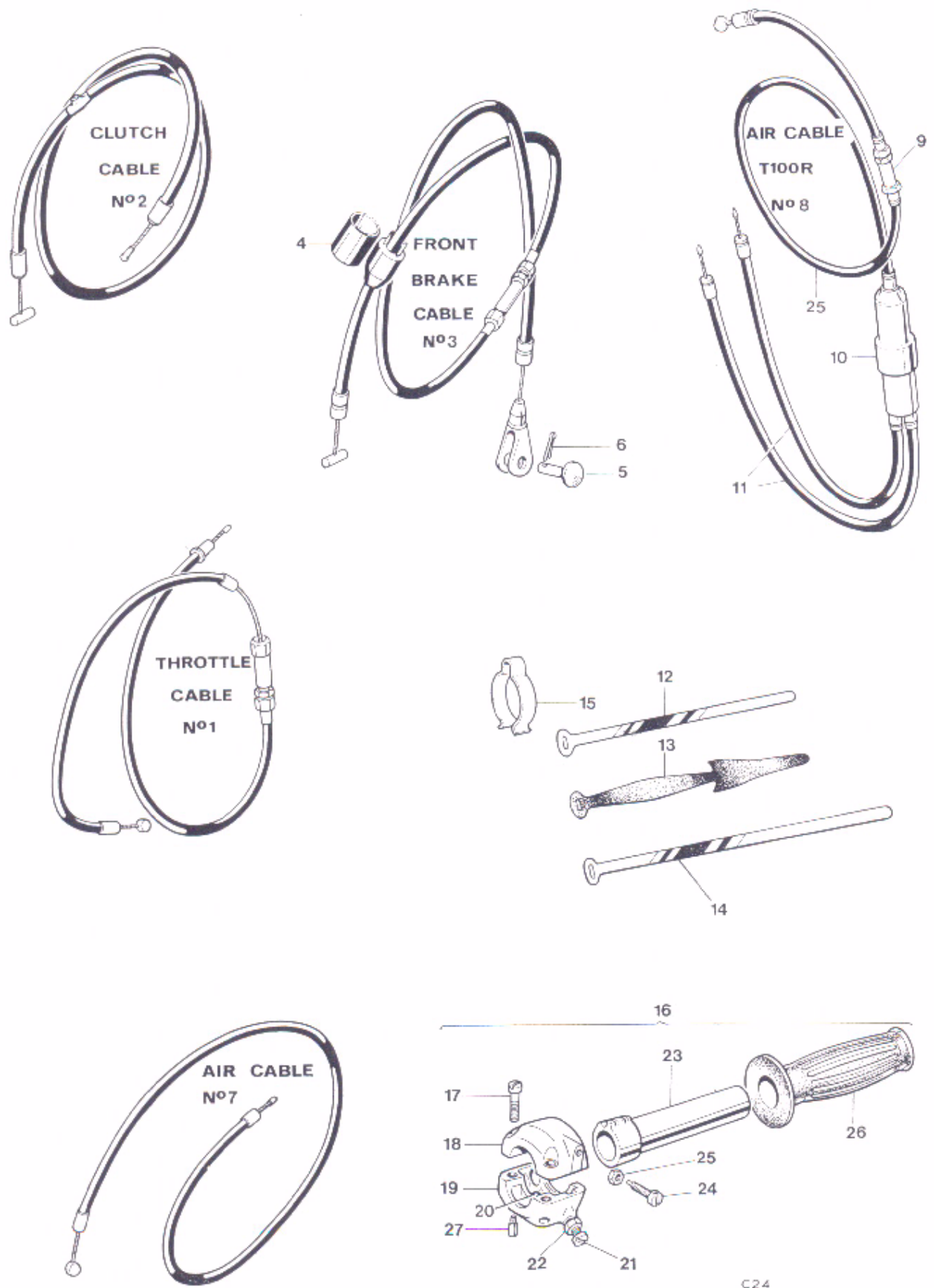

Fig. 31. CONTROL CABLES

CONTROL CABLES

1	D1823	Throttle cable	1	T100C
1	D1822	Throttle cable	2	T100R
2	D1994	Clutch cable	1	
3	D2076	Front brake cable	1	
4	D2086	Cover, stop switch	1	
5	WF32	Pivot pin	1	
6	—	Split pin		Reference only
7	D3270	Air control cable	1	T100C
8	D3271	AIR CONTROL CABLE	1	T100R
9	D3272	Cable, lever to junction box	1	
10	244/104	Junction box (99-0341)	1	
11	D745	Cable, junction box to carburetor	2	
12	XA69	Clip, metal	}	As required
13	D343/7	Clip, rubber		
14	F9918	Clip, metal		
15	H4112	Cable clip		
16	313/13	TWIN ROTOR TWISTGRIP (99-0347)	1	T100R
17	18/084	Screw	}	Reference only
18	313/020	Body, top half		
19	313/021	Body, bottom half		
20	16/008	Friction spring		
21	210/007	Screw		
22	5/077	Nut		
23	313/004	Rotor		
24	210/008	Rotor stop	}	Reference only
25	5/077	Nut		
26	H2125	Grip		
27	16/011	Cable stop	1	Reference only

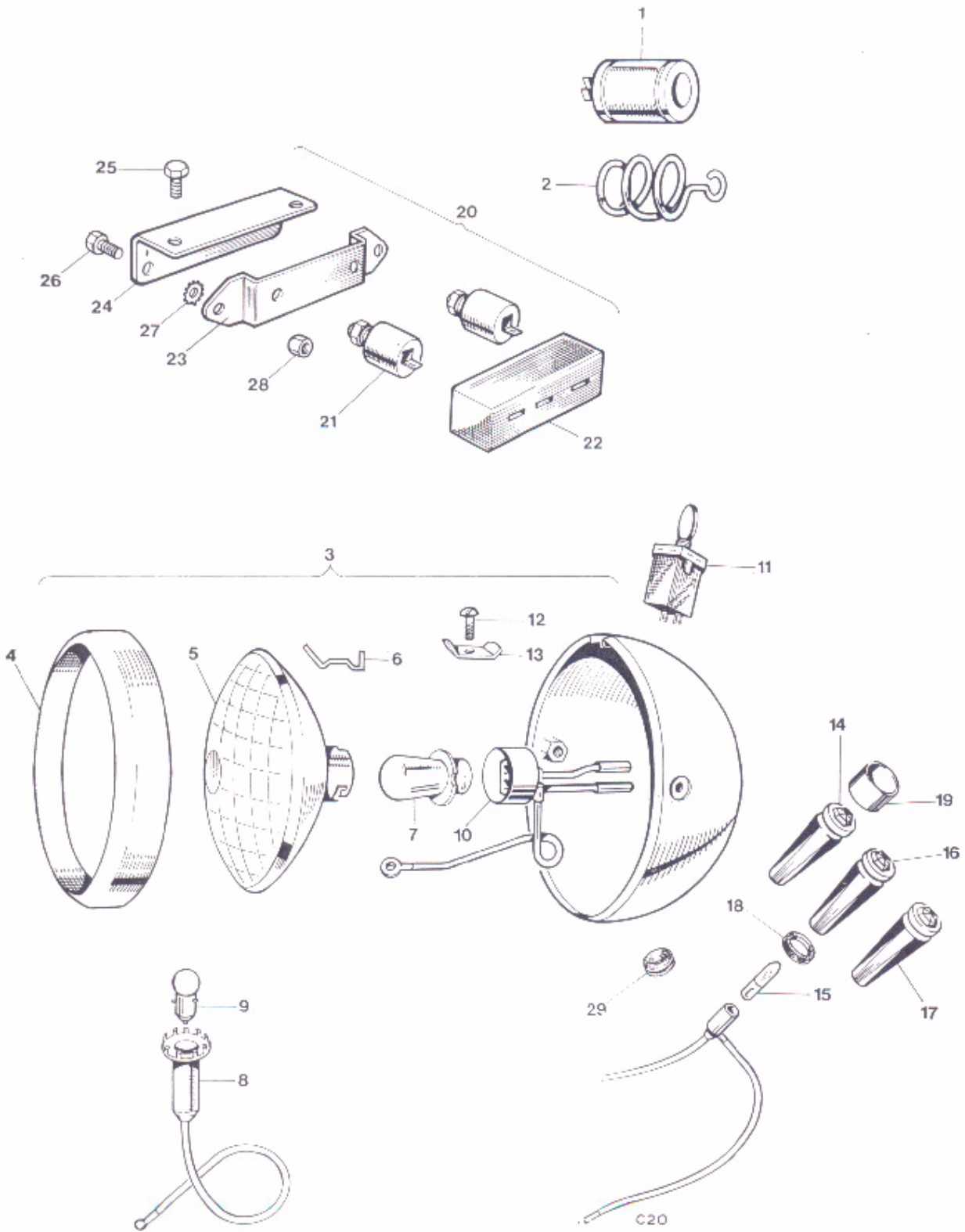

Fig. 32. T100C IGNITION CAPACITOR AND HEADLAMP

T100C IGNITION CAPACITOR AND HEADLAMP

1	54170009	Ignition capacitor (99-0737)	Available	
2	54483156	Mounting spring (99-0778)	Available	
3	60261	HEADLAMP COMPLETE—MCH66 (99-1219)	1	
4	534343	Rim (99-0691)	1	
5	54525272	Light unit (99-1212)	1	
6	504665	Fixing wire (99-0683)	6	
7	370	Main bulb (45/35 W) (99-1214)	1	
8	54573590	Bulbholder, pilot (99-0695)	1	
9	989	Pilot bulb (99-0548)	1	
10	554602	Bulbholder, main	Reference only	
11	35710	Lighting switch (99-0563)	1	
12	144921	Screw	Reference only	
13	534296	Plate	Reference only	
14	54363454	Warning light, red (99-1208)	1	
15	281	Bulb (99-0537)	3	
16	54363455	Warning light, green (99-1209)	1	
17	54363453	Warning light, amber (99-1207)	1	
18	54140331	Sealing washer (99-1210)	3	
19	54525212	Warning light shield	Reference only	
20	47638	CAPACITOR PACK—2CP	Reference only	
21	54420128	Capacitor (99-1043)	2	
22	54418528	Cover (99-0767)	1	
23	54418526	Base plate (99-1160)	1	
24	F8082	Capacitor pack bracket	1	
25	E4638	Screw, bracket to frame	2	
26	F10033	Bolt	2	
27	G5299	Shakeproof washer	2	
28	F3799	Nut	2	
29	862217	Grommet	Reference only	

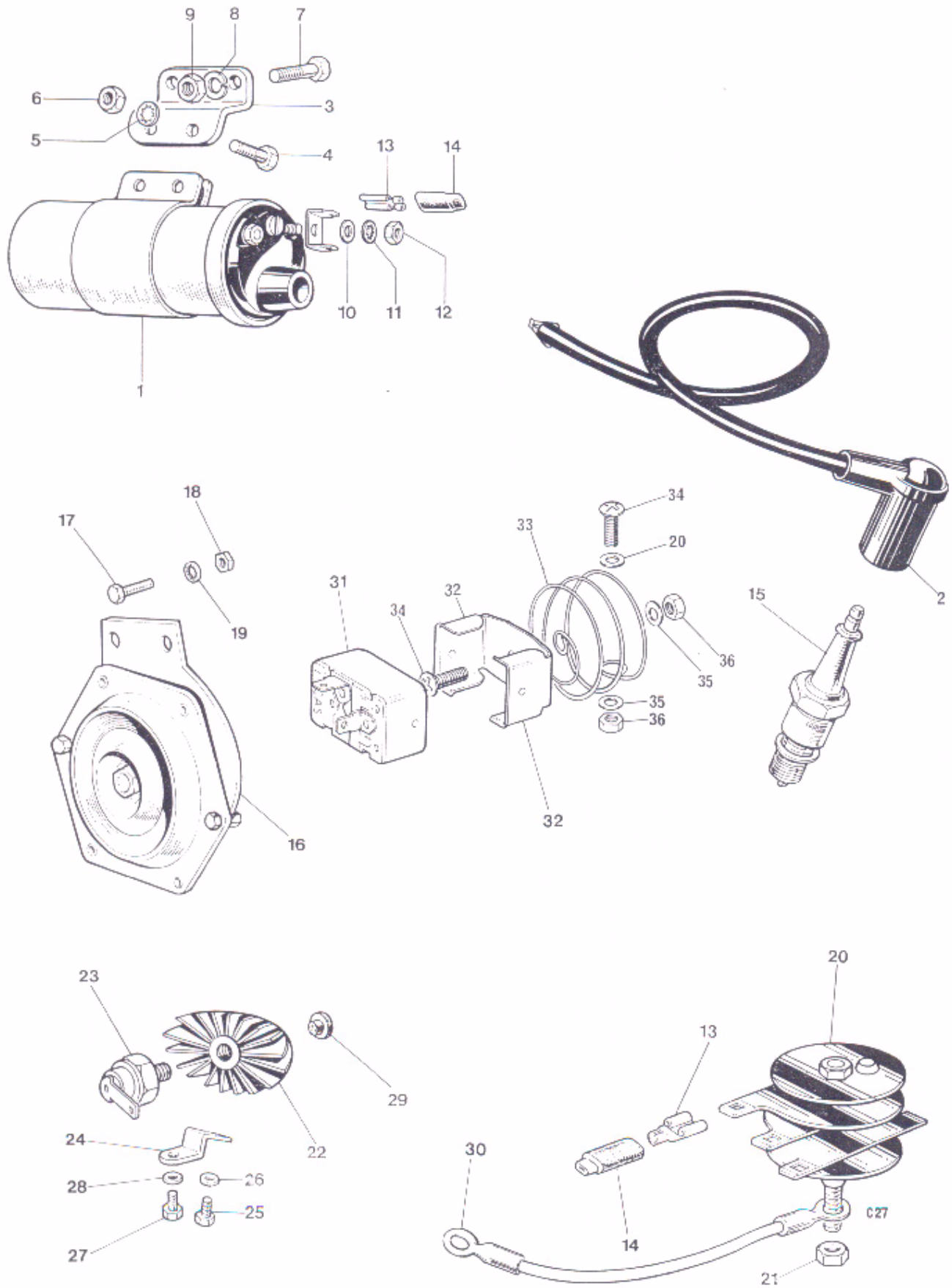

Fig. 33. IGNITION COILS, HORN, RECTIFIER AND ZENER DIODE

IGNITION COILS, HORN, RECTIFIER AND ZENER DIODE

1	45223	Ignition coil (D2206) Lucas type 17 M12	2	
2	D262	Plug cover	2	
3	F11533	Coil bracket	2	
4	14-0103	Bolt (Coil to bracket)	4	
5	S25-1	Washer	4	
6	14-1301	Nut	4	
7	14-0114	Bolt (Coil bracket to frame)	2	
8	S25-3	Washer	2	
9	14-1302	Nut	2	
10	131023	Plain washer E2351	4	
11	188330	Serrated washer (GS299)	4	
12	166043	Nut (F3799)	4	
13	54942078	Lucar connector	As required	
14	54190042	Insulating cover... ..	As required	
15	N4	Champion sparking plug	Reference only	
16	F7552	Horn (Clearhooter 27899)	1	
17	F4771	Screw ($\frac{3}{8}$ in. U.H.)	2	
18	F3799	Nut	3	
19	GS299	Serrated washer	3	
20	49072	Rectifier, type 2DS 506 (99-0589)	1	
21	F5338	Nut	1	
22	H2237	Heat sink	1	
23	49345	Zener Diode (99-0590)	1	
24	H4262	Heat sink bracket	1	
25	14-6102	Bolt	1	
26	S26-2	Washer	1	
27	14-0113	Bolt, bracket to fork lug	1	
28	S26-3	Washer	1	
29	H2275	Plug, heatsink	1	
30	54190000	Earth blade, rectifier (99-1159)	1	
31	35048	Flasher unit (99-1201)... ..	1	
32	54385091	Clip, flasher unit (99-1204)	1	
33	D3654	Spring	1	
34	F10033	Bolt	1	
35	E2351	Washer	1	
36	F4717	Nut	1	
37	S25-13	Washer	1	

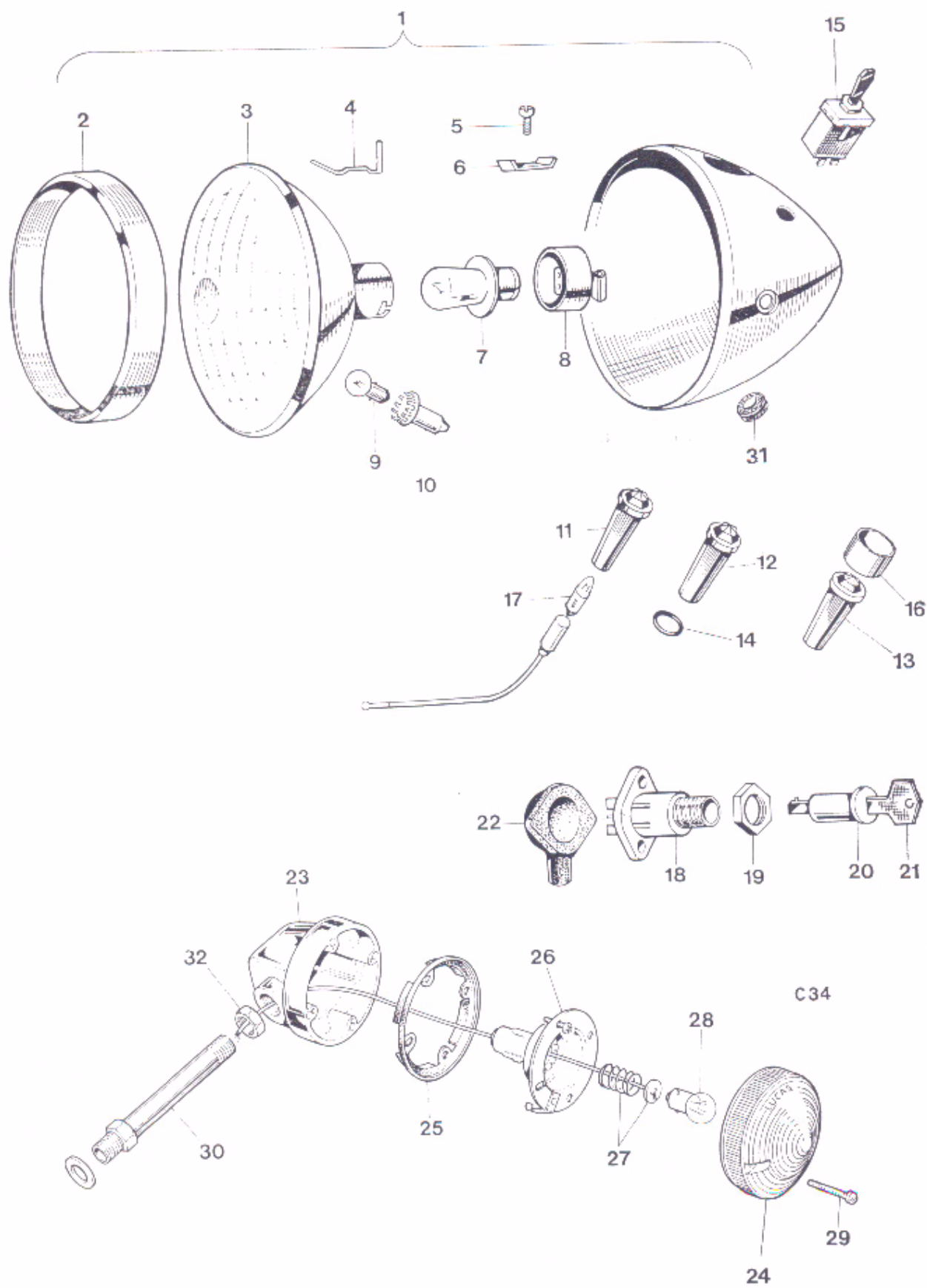

Fig. 34. HEADLAMP, WIRING HARNESS, SWITCHES AND TAIL LAMP

HEADLAMP AND FLASHER LAMPS

1	60263	HEADLAMP COMPLETE SS700P (99-1155)	1	T100R
2	553248	Rim (99-0692)	1	
3	516801	Light unit (99-1156)	1	
4	504665	Fixing wire (99-0683)	6	
5	14492	Screw		Reference only
6	534296	Plate		Reference only
7	370	Main bulb (45/35W) (99-1214)	1	
8	554602	Bulbholder		Reference only
9	989	Pilot bulb (99-0548)	1	
10	54573590	Pilot bulbholder (99-1213)	1	
11	54363454	Warning light (Red) (99-1208)	1	
12	54363455	Warning light (Green) (99-1209)	1	
13	54363453	Warning light (Amber) (99-1207)	1	
14	54140331	Sealing washer (99-1210)...	3	
15	35710	Light switch (57SA) (99-0563)	1	
16	54525212	Shield, warning light		Reference only
17	281	Bulb, warning light (99-0537)	3	
Not illus.	54959628	Wiring harness (99-1158)	1	
18	31899	IGNITION SWITCH (TYPE S45) (99-0558)	1	
19	54130041	Nut		Reference only
20	F6981	IGNITION LOCK C/W KEY	1	
21	D622	Key (state serial number)		As required
22	H2262	Cover, ignition switch	1	
23	56147	FLASHER LAMP (99-1109)	4	
24	54581638	Lens (99-1191)	1	
25	54580300	Gasket		Reference only
26	554548	Bulbholder		Reference only
27	573832	Interior assembly		Reference only
28	382	Bulb (99-1192)	1	
29	54123401	Screw (99-1193)	2	
30	60600092	Stanchion, flasher lamp (99-1246)	4	
31	862217	Grommet		Reference only
Not illus.	W2321	Shakeproof washer	4	

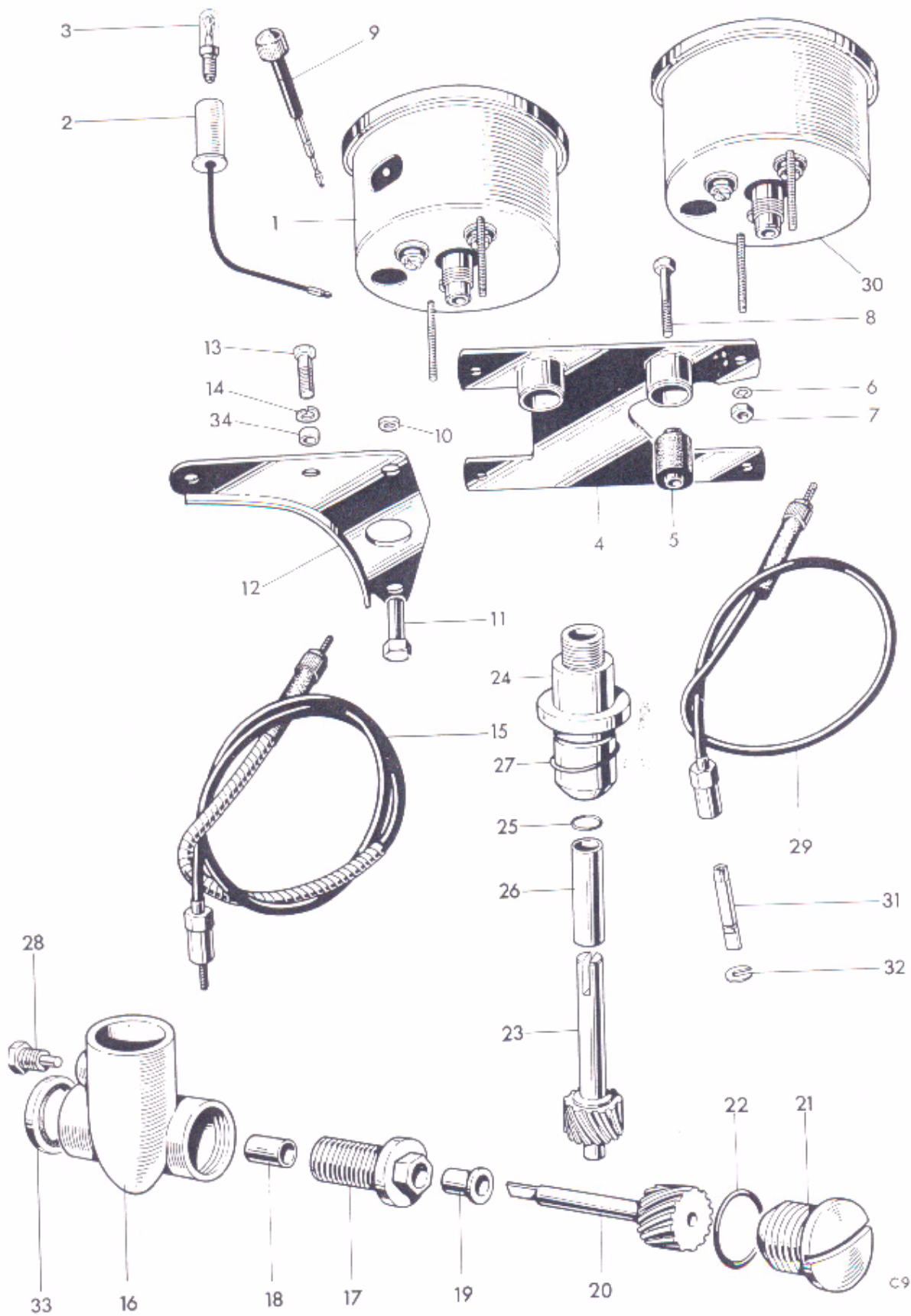

Fig. 35. SPEEDOMETER AND TACHOMETER

SPEEDOMETER AND TACHOMETER

1	SSM5007/02	Speedometer head MPH (D2402)	1	
2	54953387	Bulb holder	Reference only	
3	987	Bulb, 2.2W. M.E.S.	Reference only	
4	H1946	MOUNTING BRACKET	1	} T100R (Can be fitted to T100C)
5	H1929	Metalastik bush	2	
6	30-282-014-11	Washer	2	
7	30-276-037-11	Nut	2	
8	S590	Bolt (1 $\frac{3}{8}$ in. U.H.)	2	
9	41-148-203	Trip control	1	
10	H1702	Distance piece	2	} T100C
11	H1701	Sleeve nut	2	
12	H1668	Bracket	1	
13	14-0103	Bolt	2	
14	S26-2	Spring washer	2	
15	D692	Speedometer cable (63 ins. long) (D692W inner only)	1	
16	E9438	TACHOMETER GEARBOX (Body E5757)	1	} T100R (Can be fitted to T100C)
17	E9332	Securing screw (Left hand thread) UNF	1	
18	Reference only	Bush	1	
19	Reference only	Flanged bush	1	
20	E5157	Driving gear	1	
21	E5759	End cap	1	
22	E6300	"O" ring	1	
23	E5578	Driven gear	1	
24	E12875	Driven gear housing	1	
25	E6299	"O" ring	1	
26	Reference only	Bush	1	
27	D3522	"O" ring	1	
28	E5881	Set screw	1	
29	D648	Tachometer cable (26 $\frac{1}{2}$ in. long)	1	
30	RSM3003/13	Tachometer (D2396)	1	
31	31-371-398	Spade (99-0173)	1	
32	D494	Circlip	1	
33	E7351	Sealing washer	1	
34	F4366	Spacer	2	

WASHERS—PLAIN

<i>Part No.</i>	<i>Material</i>	<i>i/dia.</i>	<i>o/dia.</i>	<i>Thickness</i>
S25-1	Steel	0.273"	0.563"	0.048"
S25-2	Steel	0.398"	0.750"	0.063"
S25-3	Steel	0.336"	0.625"	0.063"
S25-6	Steel	0.531"	1.031"	0.092"
S25-13	Steel	0.266"	0.469"	0.064"
S25-71	Steel	0.453"	0.750"	0.064"

WASHERS—SPRING

<i>Part No.</i>	<i>Material</i>	<i>i/dia.</i>	<i>o/dia.</i>	<i>o/a height</i>	<i>Thickness</i>
S26-1	Spring Steel	$\frac{3}{8}$ " clearance	$\frac{19}{32}$ "	$\frac{7}{32}$ "	0.104"
S26-2	Spring Steel	$\frac{1}{4}$ " clearance	$\frac{13}{32}$ "	$\frac{3}{16}$ "	0.064"
S26-16	Spring Steel	$\frac{17}{32}$ "	$\frac{7}{8}$ "	$\frac{7}{32}$ "	0.040**
S648	Spring Steel	$\frac{5}{16}$ " clearance	$\frac{1}{2}$ "	$\frac{5}{32}$ "	0.080"

** Double coil.

N U T S

<i>Part No.</i>	<i>Material</i>	<i>Thd. dia.</i>	<i>Hexagon A.F.</i>	<i>Thickness</i>	<i>Remarks</i>
S778	Steel	No. 10 UNF	0.375"	0.225"	Cleveloc
S1852	"	$\frac{5}{16}$ " UNF	0.437"	0.330"	Philidas
S1906	"	$\frac{1}{4}$ " UNF	0.438"	0.188"	Plain
S1908	"	$\frac{5}{16}$ " UNF	0.438"	0.313"	Plain
S1914	"	$\frac{3}{4}$ " UNEF	1.125"	0.250"	Plain
S2012	"	$\frac{7}{8}$ " UNEF	1.313"	0.438"	Plain
S2013	"	$\frac{3}{4}$ " UNEF	1.313"	0.313"	Plain
S2014	"	$\frac{3}{4}$ " UNEF	1.313"	0.438"	Plain
14-0301	"	$\frac{1}{4}$ " UNF	0.438"	0.224"	Plain
14-0302	"	$\frac{5}{16}$ " UNF	0.500"	0.271"	Plain
14-0303	"	$\frac{3}{8}$ " UNF	0.563"	0.300"	Plain
14-0304	"	$\frac{7}{8}$ " UNF	0.688"	0.375"	Plain
14-0401	"	$\frac{1}{4}$ " UNF	0.438"	0.161"	Lock
14-0402	"	$\frac{5}{16}$ " UNF	0.500"	0.192"	Lock
14-0403	"	$\frac{3}{8}$ " UNF	0.563"	0.224"	Lock
14-0404	"	$\frac{7}{8}$ " UNF	0.688"	0.250"	Lock
14-0701	"	$\frac{1}{4}$ " UNF	0.438"	0.203"	Philidas
14-0702	"	$\frac{5}{16}$ " UNF	0.500"	0.246"	Philidas
14-0703	"	$\frac{3}{8}$ " UNF	0.563"	0.296"	Philidas
14-1201	"	$\frac{1}{4}$ " UNF	0.438"	0.285"	Stiffnut
14-1202	"	$\frac{5}{16}$ " UNF	0.500"	0.335"	Stiffnut
14-1301	"	$\frac{1}{4}$ " UNF	0.438"	0.245"	Stiffnut
14-1302	"	$\frac{5}{16}$ " UNF	0.500"	0.290"	Stiffnut
14-1303	"	$\frac{3}{8}$ " UNF	0.563"	0.320"	Stiffnut
14-1304	"	$\frac{7}{8}$ " UNF	0.688"	0.375"	Stiffnut
14-1305	"	$\frac{1}{2}$ " UNF	0.750"	0.435"	Stiffnut
14-1901	"	$\frac{1}{4}$ " UNF	0.438"	0.283"	Nyloc
14-1902	"	$\frac{5}{16}$ " UNF	0.500"	0.361"	Nyloc
14-1903	"	$\frac{3}{8}$ " UNF	0.563"	0.375"	Nyloc

S C R E W S

<i>Part No.</i>	<i>Type of head</i>	<i>Material</i>	<i>Thd. dia.</i>	<i>Length under head</i>	<i>Type of drive</i>
S1916	Cheese head	Steel	$\frac{1}{4}$ " UNC	$1\frac{1}{8}$ "	Cross recess
S1917	Cheese head	"	$\frac{1}{4}$ " UNC	$2\frac{5}{8}$ "	Cross recess
S1918	Cheese head	"	$\frac{1}{4}$ " UNC	$2\frac{3}{8}$ "	Cross recess
S1920	Hex. head	"	$\frac{1}{4}$ " UNC	$\frac{21}{64}$ "	Cross recess
S1929	Countersunk 82°	"	$\frac{1}{4}$ " UNC	$\frac{17}{32}$ "	Slot
S2079	Cheese head	"	No. 10 UNF	$\frac{1}{2}$ "	Pozidrive
14-0604	Cheese head	"	$\frac{1}{4}$ " UNF	$\frac{1}{2}$ "	Cross recess
14-6504	Countersunk (82°)	"	$\frac{1}{4}$ " UNC	$\frac{3}{4}$ "	Cross recess
14-6505	Countersunk (82°)	"	$\frac{1}{4}$ " UNC	$\frac{7}{8}$ "	Cross recess
14-6606	Cheese head	"	$\frac{1}{4}$ " UNC	$\frac{3}{4}$ "	Cross recess
14-6607	Cheese head	"	$\frac{1}{4}$ " UNC	$\frac{7}{8}$ "	Cross recess
14-6608	Cheese head	"	$\frac{1}{4}$ " UNC	1"	Cross recess
14-6609	Cheese head	"	$\frac{1}{4}$ " UNC	$1\frac{1}{4}$ "	Cross recess
14-6610	Cheese head	"	$\frac{1}{4}$ " UNC	$1\frac{1}{2}$ "	Cross recess
14-6611	Cheese head	"	$\frac{1}{4}$ " UNC	$1\frac{3}{4}$ "	Cross recess
14-6612	Cheese head	"	$\frac{1}{4}$ " UNC	2"	Cross recess
14-6613	Cheese head	"	$\frac{1}{4}$ " UNC	$2\frac{1}{4}$ "	Cross recess
14-6614	Cheese head	"	$\frac{1}{4}$ " UNC	$2\frac{1}{2}$ "	Cross recess
14-6615	Cheese head	"	$\frac{1}{4}$ " UNC	3"	Cross recess
14-7004	Socket head	"	$\frac{1}{4}$ " UNC	$\frac{1}{4}$ "	Hex. socket
14-7019	Socket head	"	$\frac{5}{16}$ "	$\frac{7}{8}$ "	Hex. socket
14-7024	Socket head	"	$\frac{5}{16}$ "	2"	Hex. socket

STANDARD HARDWARE SPECIFICATION BOLTS

Part No.	Material	Thd. dia.	Length under head	Min. length of thread	Hexagon A.F.
S1822	Steel	$\frac{5}{16}$ " UNF	$\frac{1}{2}$ "	$\frac{27}{64}$ "	0.500"
S1910	"	$\frac{3}{8}$ " UNF	$\frac{13}{16}$ "	$\frac{13}{16}$ "	0.565"
S1919	"	$\frac{5}{16}$ " UNC	$1\frac{5}{8}$ "	$\frac{7}{8}$ "	0.500"
S2010	"	$\frac{1}{4}$ " UNF	$\frac{13}{16}$ "	$\frac{3}{4}$ "	0.375"
14-0101	"	$\frac{1}{4}$ " UNF	$\frac{1}{2}$ "		0.438"
14-0102	"	$\frac{1}{4}$ " UNF	$\frac{5}{8}$ "		0.438"
14-0103	"	$\frac{1}{4}$ " UNF	$\frac{3}{4}$ "		0.438"
14-0105	"	$\frac{1}{4}$ " UNF	1"		0.438"
14-0113	"	$\frac{5}{16}$ " UNF	$\frac{5}{8}$ "		0.500"
14-0114	"	$\frac{5}{16}$ " UNF	$\frac{3}{4}$ "		0.500"
14-0115	"	$\frac{5}{16}$ " UNF	$\frac{7}{8}$ "		0.500"
14-0116	"	$\frac{5}{16}$ " UNF	1"		0.500"
14-0126	"	$\frac{3}{8}$ " UNF	$\frac{3}{4}$ "		0.563"
14-0128	"	$\frac{3}{8}$ " UNFF	1"		0.563"
14-0132	"	$\frac{7}{16}$ " UN	$\frac{7}{8}$ "		0.625"
14-0201	"	$\frac{1}{4}$ " UNF	1"	$\frac{3}{4}$ "	0.438"
14-0202	"	$\frac{1}{4}$ " UNF	$1\frac{1}{8}$ "	$\frac{3}{4}$ "	0.438"
14-0205	"	$\frac{1}{4}$ " UNF	$1\frac{1}{2}$ "	$\frac{3}{4}$ "	0.438"
14-0208	"	$\frac{1}{4}$ " UNF	$2\frac{1}{4}$ "	$\frac{3}{4}$ "	0.438"
14-0216	"	$\frac{5}{16}$ " UNF	$1\frac{1}{8}$ "	$\frac{7}{8}$ "	0.500"
14-0217	"	$\frac{5}{16}$ " UNF	$1\frac{1}{4}$ "	$\frac{7}{8}$ "	0.500"
14-0219	"	$\frac{5}{16}$ " UNF	$1\frac{1}{2}$ "	$\frac{7}{8}$ "	0.500"
14-0220	"	$\frac{5}{16}$ " UNF	$1\frac{3}{4}$ "	$\frac{7}{8}$ "	0.500"
14-0221	"	$\frac{5}{16}$ " UNF	2"	$\frac{7}{8}$ "	0.500"
14-0222	"	$\frac{5}{16}$ " UNF	$2\frac{1}{4}$ "	$\frac{7}{8}$ "	0.500"
14-0225	"	$\frac{5}{16}$ " UNF	3"	$\frac{7}{8}$ "	0.500"
14-0228	"	$\frac{5}{16}$ " UNF	4"	$\frac{7}{8}$ "	0.500"
14-0234	"	$\frac{3}{8}$ " UNF	$1\frac{3}{4}$ "	1"	0.563"
14-0235	"	$\frac{3}{8}$ " UNF	2"	1"	0.563"
14-0236	"	$\frac{3}{8}$ " UNF	$2\frac{1}{4}$ "	1"	0.563"
14-0237	"	$\frac{3}{8}$ " UNF	$2\frac{1}{2}$ "	1"	0.563"
14-0239	"	$\frac{3}{8}$ " UNF	3"	1"	0.563"
14-0241	"	$\frac{3}{8}$ " UNF	$3\frac{1}{2}$ "	1"	0.563"
14-0242	"	$\frac{3}{8}$ " UNF	4"	1"	0.563"
14-0251	"	$\frac{7}{16}$ " UNF	$2\frac{3}{4}$ "	$1\frac{1}{4}$ "	0.625"
14-6101	"	$\frac{1}{4}$ " UNC	$\frac{1}{2}$ "		0.438"
14-6102	"	$\frac{1}{4}$ " UNC	$\frac{5}{8}$ "		0.438"
14-6115	"	$\frac{5}{16}$ " UNC	$\frac{7}{8}$ "		0.500"
14-6121	"	$\frac{5}{16}$ " UNC	$2\frac{1}{2}$ "		0.500"